

La Boutique 83

inox



SOMMAIRE

POTEAUX TARAUDÉS ET EMBASES - NOUVEAU



TUBES RONDS FINITION



FIXATIONS À L'ANGLAISE



SUPPORTS DE MAINS COURANTES



CONNECTEURS POUR TUBES RONDS



TUBES CARRÉS ET CONNECTEURS POUR TUBES CARRÉS - NOUVEAU



SYSTÈMES MAINS COURANTES BOIS



CONNECTEURS EN APPLIQUE ET POUR POSE PLEXIGLAS - NOUVEAU



PINCES À VERRE INOX 316 ET ZAMAC



GARDES CORPS EN VERRE



CÂBLES INOX 316 ET TENDEURS AVEC OU SANS SERTISSAGE



OUTILLAGES ET VISSERIES



COLLES ET PRODUITS DE FINITION



POTEAUX ET PLATINES

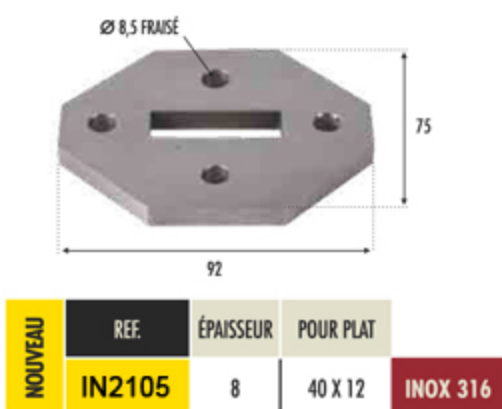
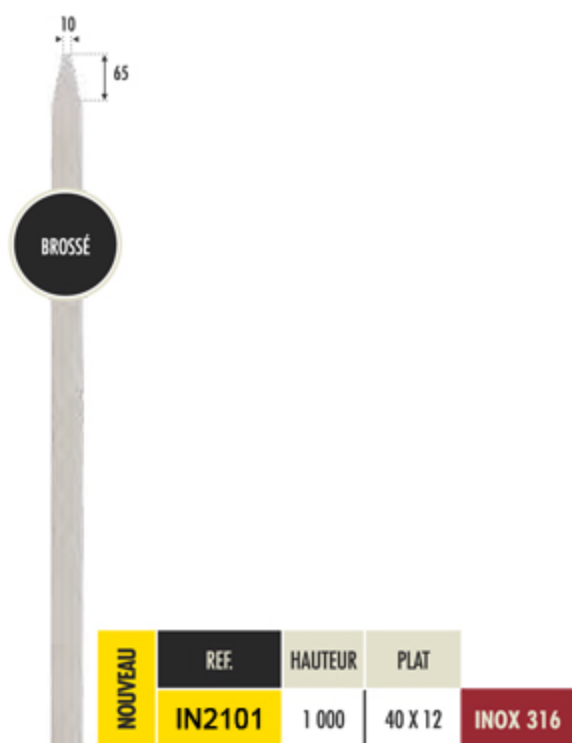

POTEAUX TARAUDÉS MONTAGE CÂBLE OU ROND PLEIN

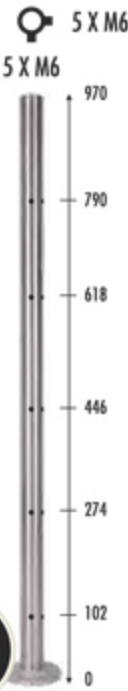
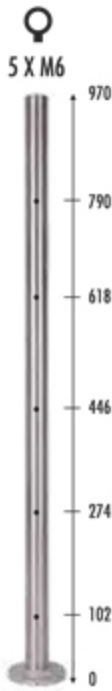

INOX 316	NOUVEAU	REF.	HAUTEUR	Ø DU TUBE
		IN2121	970	42,4

INOX 316	NOUVEAU	REF.	HAUTEUR	Ø DU TUBE
		IN2122	970	42,4

POTEAUX TARAUDÉS MONTAGE VERRE



INOX 316	NOUVEAU	REF.	HAUTEUR	Ø DU TUBE
		IN2123	970	42,4



INOX 316	NOUVEAU	REF.	HAUTEUR	Ø DU TUBE
		IN2124	970	42,4



INOX 316	NOUVEAU	REF.	HAUTEUR	Ø DU TUBE
		IN2125	970	42,4

POTEAUX TARAUDÉS MONTAGE CÂBLE ET VERRE

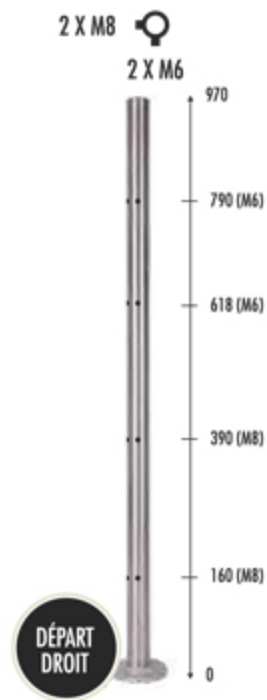
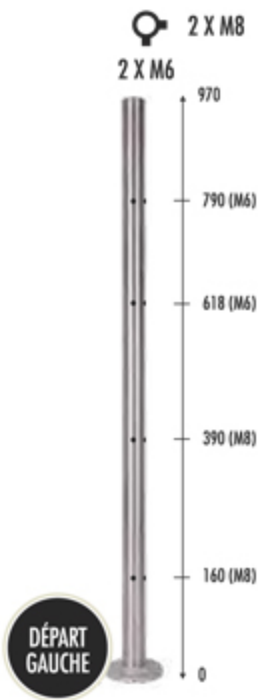

INOX 316	NOUVEAU	REF.	HAUTEUR	Ø DU TUBE
		IN2126	970	42,4

INOX 316	NOUVEAU	REF.	HAUTEUR	Ø DU TUBE
		IN2127	970	42,4

POTEAUX TARAUDÉS MONTAGE CÂBLE ET VERRE

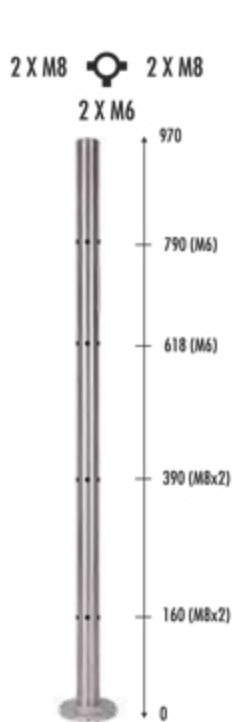

INOX 316	NOUVEAU	REF.	HAUTEUR	Ø DU TUBE
		IN2128	970	42,4

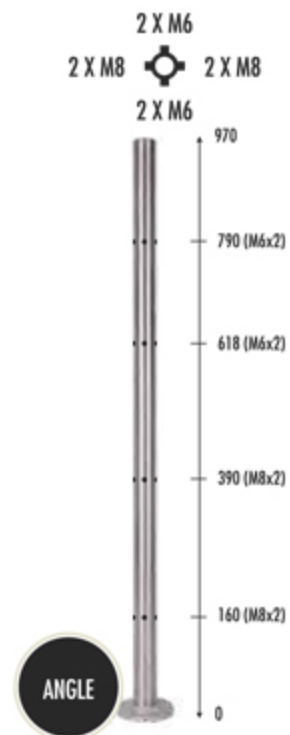

INOX 316	NOUVEAU	REF.	HAUTEUR	Ø DU TUBE
		IN2129	970	42,4

SYSTÈMES POUR MARCHES

	REF.	FILETAGE	
NOUVEAU	IN2190	M12	INOX 304
	IN2191	M12	INOX 316



CLÉ DE SERRAGE REF. 30 807 P.56 ET TIGES FILETÉES M 12 P.57

	REF.	Ø DU TUBE	
NOUVEAU	IN2192	42,4	INOX 304



	REF.	Ø DU TUBE	
NOUVEAU	IN2193	42,4	CAOUTCHOUC

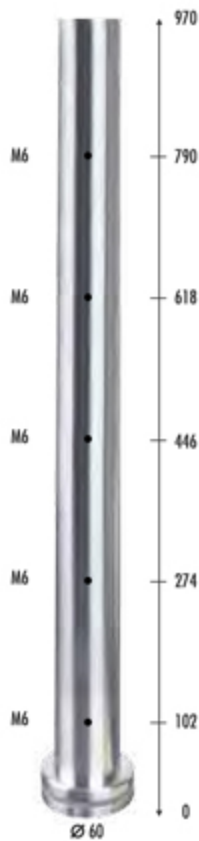
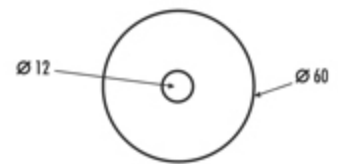

	REF.	HAUTEUR	Ø DU TUBE	TARAUDAGE	
NOUVEAU	IN2150	970	42,4	5 X M6	INOX 304

	REF.	HAUTEUR	Ø DU TUBE	
	IN2151	970	42,4	INOX 304

EMBASES POTEAUX

	REF.	Ø DU TUBE	
	IN2200	42,4	INOX 304
NOUVEAU	IN2201	42,4	INOX 316

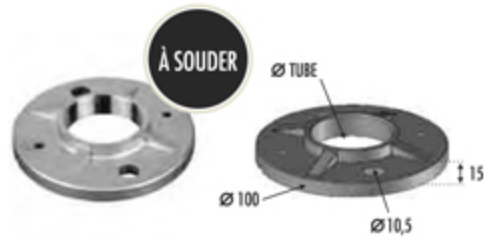

	REF.	Ø DU TUBE	
	IN2202	42,4	INOX 304
	IN2203	48,3	INOX 304
NOUVEAU	IN2204	42,4	INOX 316

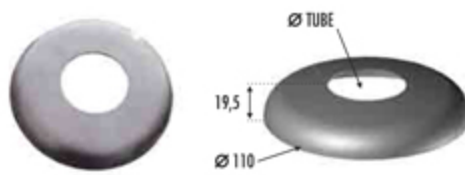

	REF.	Ø DU TUBE	
NOUVEAU	IN2154	42,4	INOX 316

TUBES 42,4 PRÉPERCÉS

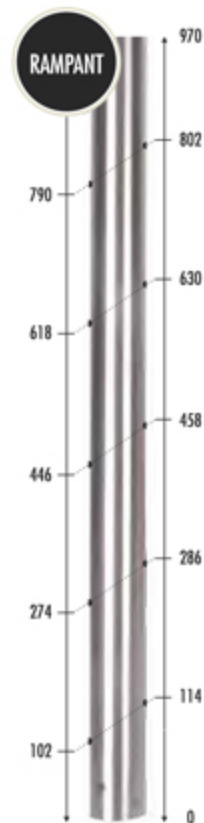
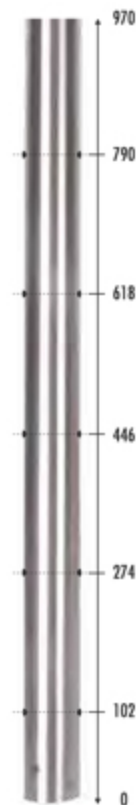

INOX 316	NOUVEAU	REF.	HAUTEUR	Ø DU TUBE	PERÇAGE
		IN2152	970	42,4	5 X Ø 8,5

INOX 316	NOUVEAU	REF.	HAUTEUR	Ø DU TUBE	PERÇAGE	POUR PENTE
		IN2153	970	42,4	5 X Ø 8,5	32°

POTEAUX TUBE INOX 42,4

ÉPAISSEUR 2 mm



POTEAU POUR PENTE DE 5 À 7 %
NORME PERSONNE À MOBILITÉ RÉDUITE

GRAIN 320



INOX 304	REF.	HAUTEUR	Ø DU TUBE
	IN2170	900	42,4



INOX 304	REF.	HAUTEUR	Ø DU TUBE	FLÈCHE
	IN2171	900	42,4	40 mm

POTEAUX TUBE INOX 42,4

ÉPAISSEUR 2 mm

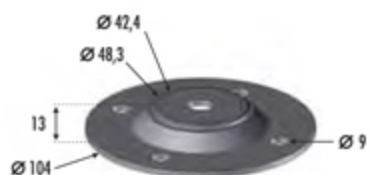

	REF.	Ø DU TUBE	
	IN2210	42,4 / 48,3	INOX 304
NOUVEAU	IN2211	42,4 / 48,3	INOX 316

PLACER LA PLATINE



VISSER



SCELLER OU VISSER

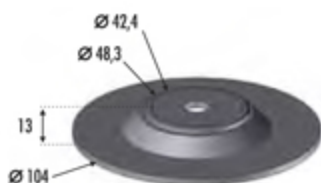

	REF.	Ø DU TUBE	
	IN2215	42,4 / 48,3	INOX 304
NOUVEAU	IN2216	42,4 / 48,3	INOX 316



	REF.	Ø DU TUBE	
	IN2202	42,4	INOX 304
	IN2203	48,3	INOX 304
NOUVEAU	IN2204	42,4	INOX 316



	REF.	Ø DU TUBE	
	IN2180	42,4	INOX 304
	IN2181	48,3	INOX 304
NOUVEAU	IN2182	42,4	INOX 316

TUBES BROSSÉS GRAIN 320



REF.	Ø DU TUBE	ÉPAISSEUR	LONGUEUR	
IN2230	42,4	2 mm	3 m	INOX 304
IN2231	48,3	2 mm	3 m	INOX 304
NOUVEAU	IN2232	42,4	2 mm	INOX 316

FINITIONS POUR TUBES INOX / ÉPAISSEUR 2 mm



REF.	Ø DU TUBE	
IN2240	42,4	INOX 304
IN2241	48,3	INOX 304
NOUVEAU	IN2242	INOX 316



REF.	Ø DU TUBE	
IN2245	42,4	INOX 304
IN2246	48,3	INOX 304
NOUVEAU	IN2247	INOX 316



REF.	Ø DU TUBE	
IN2250	42,4	INOX 304
IN2251	48,3	INOX 304
NOUVEAU	IN2252	INOX 316

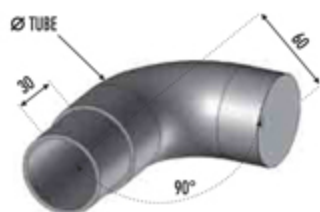

REF.	Ø DU TUBE	
IN2255	42,4	INOX 304
IN2256	48,3	INOX 304
NOUVEAU	IN2257	INOX 316

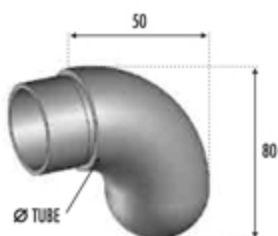

REF.	Ø DU TUBE	
IN2260	42,4	INOX 304
NOUVEAU	IN2262	INOX 316

FIXATIONS À L'ANGLAISE POUR TUBES 42,4

ÉPAISSEUR 2 mm

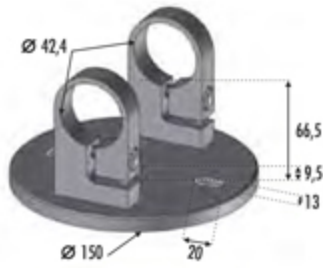

	REF.	Ø DU TUBE	
	IN2265	42,4	INOX 304
NOUVEAU	IN2266	42,4	INOX 316

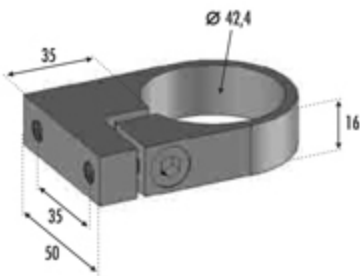

	REF.	Ø DU TUBE	
	IN2269	42,4	INOX 304
NOUVEAU	IN2270	42,4	INOX 316

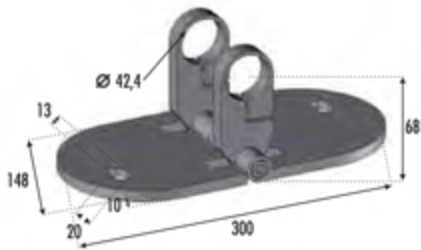

	REF.	Ø DU TUBE	
	IN2273	42,4	INOX 304
NOUVEAU	IN2274	42,4	INOX 316

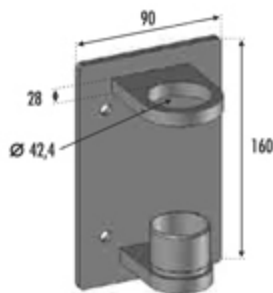

	REF.	Ø DU TUBE	
	IN2277	42,4	INOX 304
NOUVEAU	IN2278	42,4	INOX 316

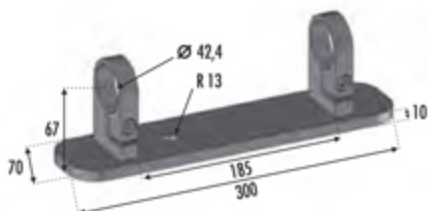

	REF.	Ø DU TUBE	
	IN2281	42,4	INOX 304
NOUVEAU	IN2282	42,4	INOX 316

ÉQUERRES DE RAMPES MURAUX



	REF.	Ø DU TUBE	
	IN2283	42,4	INOX 304
	IN2284	48,3	INOX 304
NOUVEAU	IN2285	42,4	INOX 316

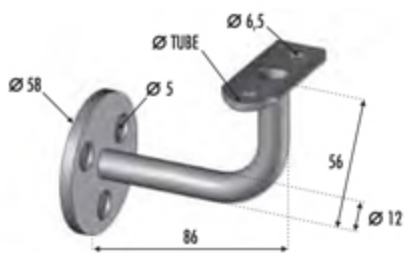

	REF.	Ø DU TUBE	
	FK3106	42,4	INOX 304
	FK3107	48,3	INOX 304
NOUVEAU	FK3108	42,4	INOX 316



	REF.	Ø DU TUBE	
	FK3104	42,4	INOX 304
	FK3105	48,3	INOX 304
NOUVEAU	FK3109	42,4	INOX 316



	REF.	Ø DU TUBE	
	IN2288	42,4	INOX 304
	IN2289	48,3	INOX 304



	REF.	FIXATION	
	IN2292	PLAT	INOX 304

SUPPORTS DE MAINS COURANTES



	REF.	Ø DU TUBE	
	IN2295	42,4	INOX 304
	IN2296	48,3	INOX 304
NOUVEAU	IN2297	42,4	INOX 316



	REF.	Ø DU TUBE	
	IN2299	42,4	INOX 304
	IN2300	48,3	INOX 304
NOUVEAU	IN2301	42,4	INOX 316



	REF.	Ø DU TUBE	
	IN2303	42,4	INOX 304
	IN2304	48,3	INOX 304
NOUVEAU	IN2305	42,4	INOX 316



	REF.	Ø DU TUBE	
	IN2307	42,4	INOX 304
	IN2308	48,3	INOX 304
NOUVEAU	IN2309	42,4	INOX 316

SUPPORTS DE MAINS COURANTES / DÉPORTÉS MURAUX



REF.	Ø DU TUBE	
IN2314	42,4	INOX 304



REF.	Ø DU TUBE	
IN2315	42,4	INOX 304

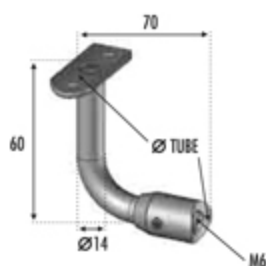

REF.	Ø DU TUBE	
IN2319	42,4	INOX 304

SUPPORTS DÉPORTÉS MURAUX

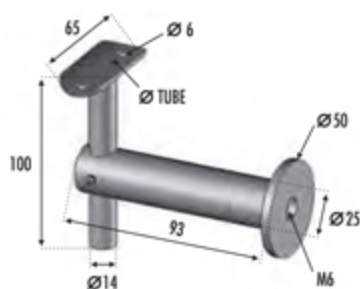

REF.	Ø DU TUBE	
IN2324	42,4	INOX 304

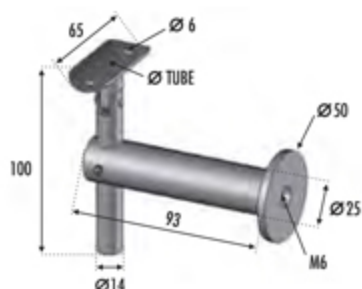

REF.	Ø DU TUBE	
IN2327	42,4	INOX 304

SUPPORTS DE MAINS COURANTES



	REF.	Ø DU TUBE	
	IN2330	42,4	INOX 304
	IN2331	48,3	INOX 304
NOUVEAU	IN2332	42,4	INOX 316

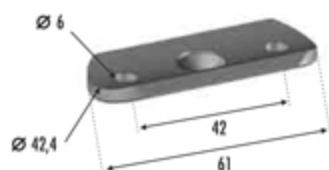

	REF.	Ø DU TUBE	
	IN2334	PLAT	INOX 304
	IN2335	42,4	INOX 304
	IN2336	48,3	INOX 304
NOUVEAU	IN2337	PLAT	INOX 316
NOUVEAU	IN2338	42,4	INOX 316



	REF.	Ø DU TUBE	
	IN2340	42,4	INOX 304
NOUVEAU	IN2342	42,4	INOX 316

CONNEXIONS DE TUBES RONDS

POUR TUBE ÉPAISSEUR 2 mm

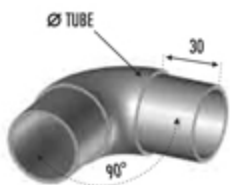

	REF.	Ø DU TUBE	
	IN2350	42,4	INOX 304
	IN2351	48,3	INOX 304
NOUVEAU	IN2352	42,4	INOX 316

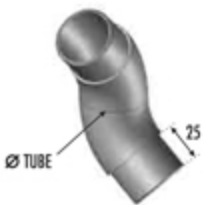

	REF.	Ø DU TUBE	
	IN2354	42,4	INOX 304
	IN2355	48,3	INOX 304
NOUVEAU	IN2356	42,4	INOX 316



	REF.	Ø DU TUBE	
	IN2358	42,4	INOX 304
	IN2359	48,3	INOX 304
NOUVEAU	IN2360	42,4	INOX 316

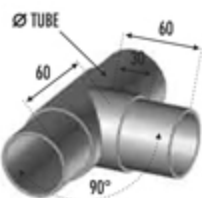

	REF.	Ø DU TUBE	
	IN2362	42,4	INOX 304
	IN2363	48,3	INOX 304
NOUVEAU	IN2364	42,4	INOX 316

CONNEXIONS DE TUBES RONDS

POUR TUBE ÉPAISSEUR 2 mm

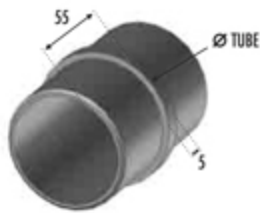

	REF.	Ø DU TUBE	
	IN2366	42,4	INOX 304
	IN2367	48,3	INOX 304
NOUVEAU	IN2368	42,4	INOX 316

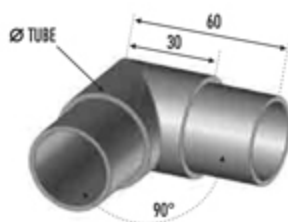

	REF.	Ø DU TUBE	
	IN2370	42,4	INOX 304
	IN2371	48,3	INOX 304
NOUVEAU	IN2372	42,4	INOX 316

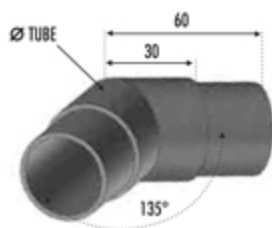

	REF.	Ø DU TUBE	
	IN2374	42,4	INOX 304
	IN2375	48,3	INOX 304
NOUVEAU	IN2376	42,4	INOX 316



	REF.	Ø DU TUBE	
	IN2378	42,4	INOX 304
	IN2379	48,3	INOX 304
NOUVEAU	IN2380	42,4	INOX 316

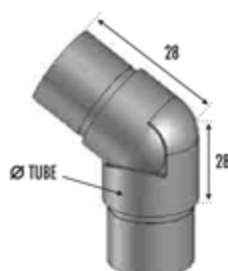

	REF.	Ø DU TUBE	
	IN2382	42,4	INOX 304
NOUVEAU	IN2383	42,4	INOX 316

CONNEXIONS DE TUBES RONDS

POUR TUBE ÉPAISSEUR 2 mm

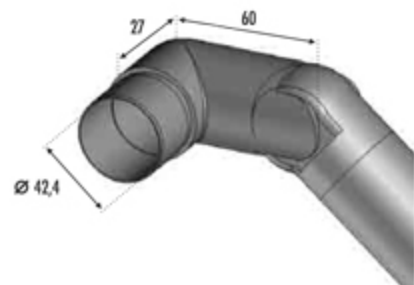
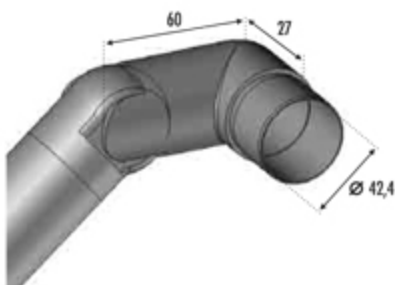

	REF.	Ø DU TUBE	
NOUVEAU	IN2385	42,4	INOX 304
	IN2387	42,4	INOX 316

	REF.	Ø DU TUBE	
NOUVEAU	IN2389	42,4	INOX 304
	IN2391	42,4	INOX 316

CONNEXIONS DE TUBES RONDS / FIXATIONS MURAUX

POUR TUBE ÉPAISSEUR 2 mm

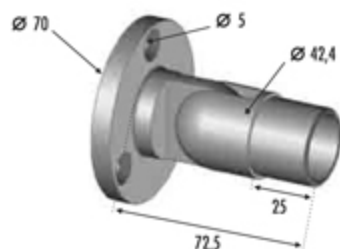

	REF.	Ø DU TUBE	
NOUVEAU	IN2393	42,4	INOX 304
	IN2395	42,4	INOX 316

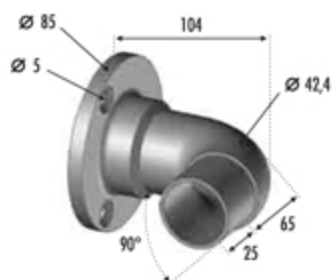

	REF.	Ø DU TUBE	
NOUVEAU	IN2397	42,4	INOX 304
	IN2399	42,4	INOX 316

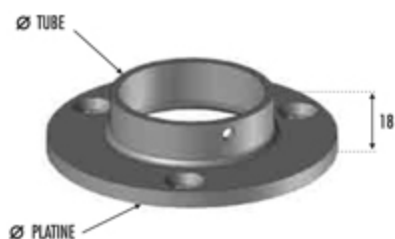

REF.	Ø DU TUBE	Ø PLATINE	
IN2401	42,4	85	INOX 304
IN2402	48,3	90	INOX 304

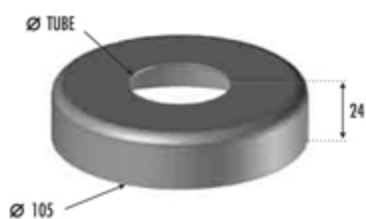

REF.	Ø DU TUBE	
IN2405	42,4	INOX 304
IN2406	48,3	INOX 304

TUBES CARRÉS 40 mm ET CONNECTEURS

POUR TUBE ÉPAISSEUR 2 mm

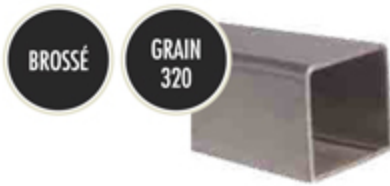

	REF.	∅ DU TUBE	ÉPAISSEUR	LONGEUR	
NOUVEAU	IN2410	40	2 mm	3 m	INOX 316

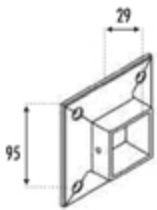

	REF.	∅ DU TUBE	
NOUVEAU	IN2412	40	INOX 316

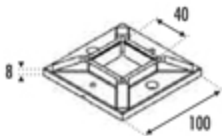

	REF.	∅ DU TUBE	
NOUVEAU	IN2414	40	INOX 316

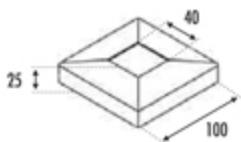

	REF.	∅ DU TUBE	
NOUVEAU	IN2416	40	INOX 316

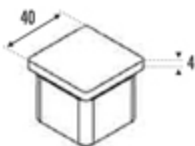

	REF.	∅ DU TUBE	
NOUVEAU	IN2418	40	INOX 316



	REF.	∅ DU TUBE	
NOUVEAU	IN2420	40	INOX 316

SUPPORTS DE MAINS COURANTES ET CONNECTEURS

POUR TUBE ÉPAISSEUR 2 mm

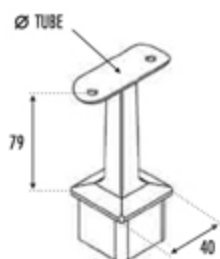

	REF.	Ø DU TUBE	
NOUVEAU	IN2422	40	INOX 316

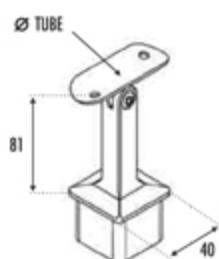

	REF.	Ø DU TUBE	
NOUVEAU	IN2424	40	INOX 316

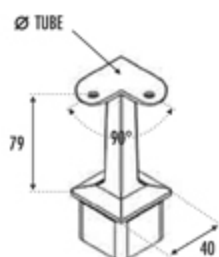

	REF.	Ø DU TUBE	
NOUVEAU	IN2426	40	INOX 316

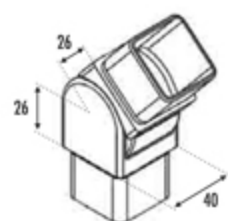

	REF.	Ø DU TUBE	
NOUVEAU	IN2428	40	INOX 316

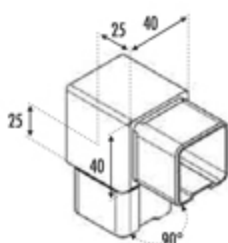

	REF.	Ø DU TUBE	
NOUVEAU	IN2430	40	INOX 316

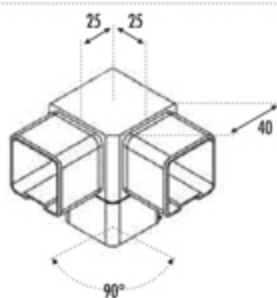

	REF.	Ø DU TUBE	
NOUVEAU	IN2432	40	INOX 316

CONNECTEURS POUR MAINS COURANTES EN BOIS

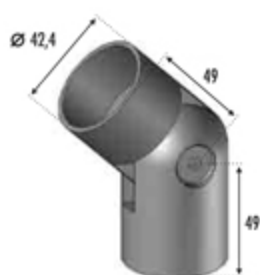

	REF.	Ø DU TUBE	
	IN2440	42,4	INOX 304
NOUVEAU	IN2442	42,4	INOX 316

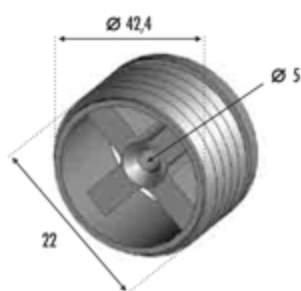

	REF.	Ø DU TUBE	
	IN2444	42,4	INOX 304

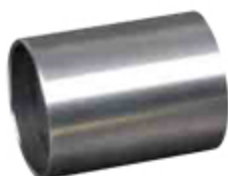
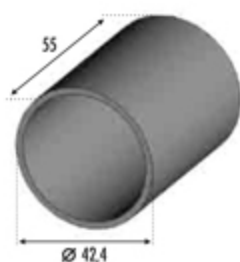

	REF.	Ø DU TUBE	
	IN2444	42,4	INOX 304
NOUVEAU	IN2450	42,4	INOX 316

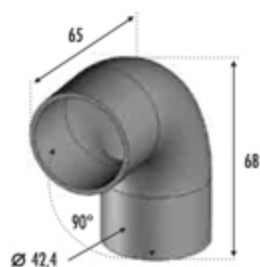

	REF.	Ø DU TUBE	
	IN2452	42,4	INOX 304
NOUVEAU	IN2454	42,4	INOX 316

FINITIONS POUR MAINS COURANTES EN BOIS

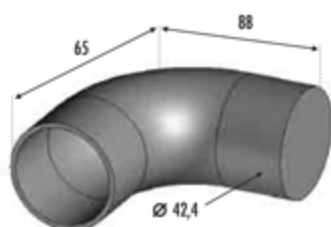

	REF.	Ø DU TUBE	
	IN2456	42,4	INOX 304
NOUVEAU	IN2458	42,4	INOX 316

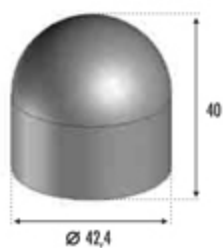

	REF.	Ø DU TUBE	
	IN2460	42,4	INOX 304
NOUVEAU	IN2462	42,4	INOX 316

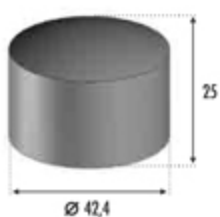

	REF.	Ø DU TUBE	
	IN2464	42,4	INOX 304
NOUVEAU	IN2466	42,4	INOX 316

MAINS COURANTES EN BOIS

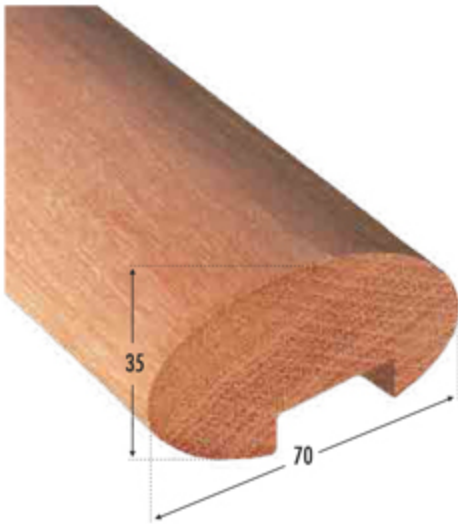

	REF.	LONGUEUR	PLAT	
NOUVEAU	FK3100	2 000	20 X 10	SAPELLI
	FK31001	2 800	20 X 10	SAPELLI

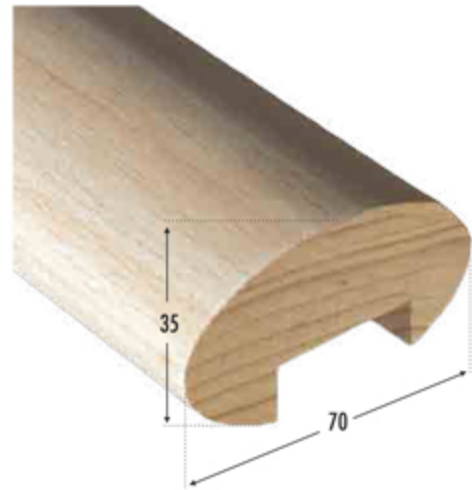

	REF.	LONGUEUR	PLAT	
NOUVEAU	FK3090	2 000	20 X 10	HÊTRE
	FK30901	2 800	20 X 10	HÊTRE



	REF.	LONGUEUR	Ø	
	FK30011	2 000	42	SAPELLI
	FK3101	2 000	48	SAPELLI
NOUVEAU	FK31012	2 800	42	SAPELLI

	REF.	LONGUEUR	Ø	
	FK3091	2 000	42	HÊTRE
	FK3092	2 000	48	HÊTRE
NOUVEAU	FK30911	2 800	42	HÊTRE

MAINS COURANTES EN BOIS



MARCHES TOUTES DIMENSIONS
DEVIS SUR PLANS
☎ N'HÉSITÉS PAS À NOUS CONSULTER

NOUVEAU	REF.	DIMENSION	ÉPAISSEUR	
	FK31039	760 X 250	35	HÊTRE



REF.	Ø
FK3097	42
FK3098	48



REF.	CONDITIONNEMENT
FK3099	SACHET DE 20 TOURILLONS



	REF.	Ø	
	FK3093	42	HÊTRE
	FK3094	48	HÊTRE
NOUVEAU	FK31021	42	SAPELLI
	FK3102	48	SAPELLI



	REF.	Ø	
	FK3095	42	HÊTRE
	FK3096	48	HÊTRE
NOUVEAU	FK31031	42	SAPELLI
	FK3103	48	SAPELLI

ENCADREMENT DE TÔLE 1,5

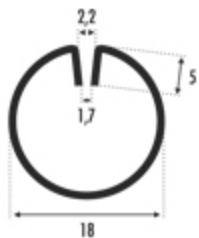

REF.	LONGUEUR	
IN2470	3 000	INOX 304

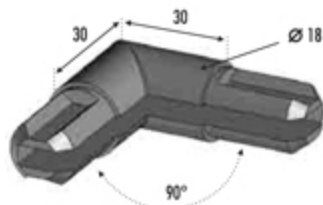

REF.	DESCRIPTION	
IN2472	RACCORD D'ANGLE	INOX 304

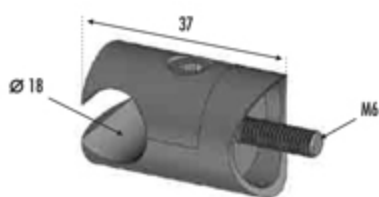

REF.	Ø DU TUBE	
IN2474	42,4	INOX 304

LIVRÉES
AVEC VIS

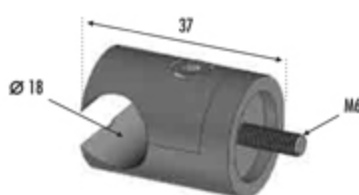

REF.	FIXATION	
IN2476	PLAT	INOX 304

PINCES À TÔLE



REF.	Ø DU TUBE	ÉPAISSEUR DE LA TÔLE	
IN2478	42,4	DE 1 À 4 MM	INOX 304
IN2480	48,3	DE 1 À 4 MM	INOX 304

LIVRÉES
AVEC VIS



REF.	FIXATION	ÉPAISSEUR DE LA TÔLE	
IN2482	PLAT	DE 1 À 4 MM	INOX 304

RONDS INOX BROSSÉS



	REF.	Ø	LONGUEUR	
	IN2490	10	3 000	INOX 304
	IN2491	12	3 000	INOX 304
	IN2492	14	3 000	INOX 304
NOUVEAU	IN2493	10	3 000	INOX 316
	IN2494	12	3 000	INOX 316
	IN2495	14	3 000	INOX 316

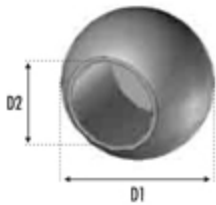

	REF.	D1	D2	
	IN2496	16,5	10	INOX 304
	IN2497	17,5	12	INOX 304
	IN2498	18,5	14	INOX 304
NOUVEAU	IN2499	16,5	10	INOX 316
	IN2500	17,5	12	INOX 316
	IN2501	18,5	14	INOX 316



	REF.	Ø INTÉRIEUR	
	IN2502	10	INOX 304
	IN2503	12	INOX 304
	IN2504	14	INOX 304
NOUVEAU	IN2505	10	INOX 316
	IN2506	12	INOX 316
	IN2507	14	INOX 316

CONNECTEURS EN APPLIQUE POUR RONDS INOX BROSSÉS

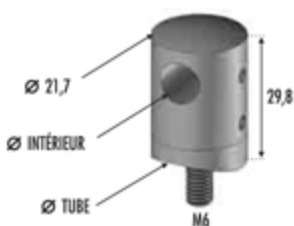

	REF.	FIXATION	Ø INTÉRIEUR	
	IN2508	42,4	10	INOX 304
	IN2509	48,3	10	INOX 304
	IN2510	PLAT	10	INOX 304
NOUVEAU	IN2513	PLAT	10	INOX 316
	IN2514	42,4	12	INOX 304
NOUVEAU	IN2517	42,4	12	INOX 316
	IN2515	48,3	12	INOX 304
	IN2516	PLAT	12	INOX 304
	IN2520	42,4	14	INOX 304
NOUVEAU	IN2523	42,4	14	INOX 316
	IN2521	48,3	14	INOX 304
	IN2522	PLAT	14	INOX 304

CONNECTEURS EN APPLIQUE POUR POSE PLEXI DE 8 mm



Montage PENDANT la réalisation du garde corps

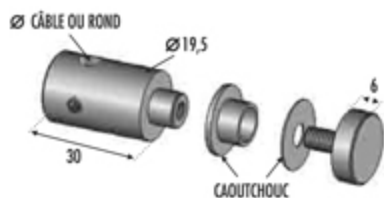

	REF.	PLEXI	Ø CÂBLE	
NOUVEAU	IN2530	8	4 mm	INOX 316
	IN2531	8	6 mm	INOX 316



	REF.	PLEXI	Ø ROND	
NOUVEAU	IN2532	8	10 mm	INOX 316

Montage APRÈS la réalisation du garde corps

EXCLUSIVITÉ

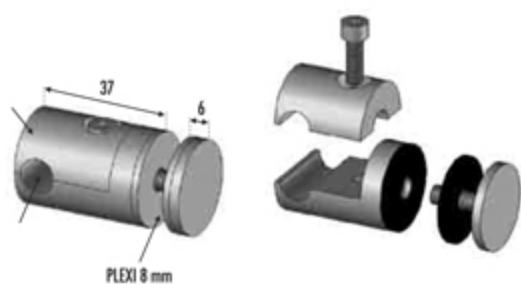

	REF.	PLEXI	Ø	
NOUVEAU	IN2533	8	10 mm	INOX 316

PINCES À VERRE CARRÉES 55 mm

CAOUTCHOUC À COMMANDER EN FONCTION DE VOTRE ÉPAISSEUR DE VERRE / LIVRÉE AVEC SES VIS DE FIXATION 8 X 20

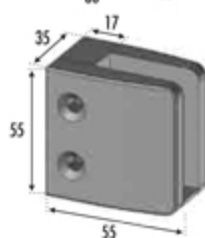
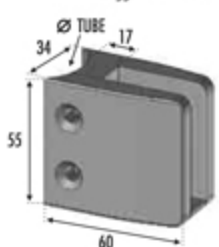
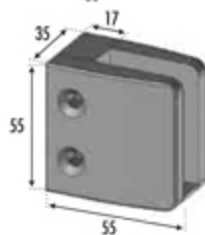
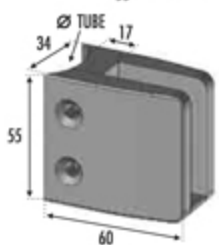
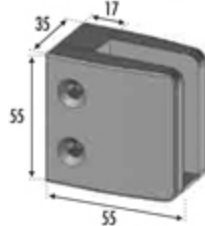
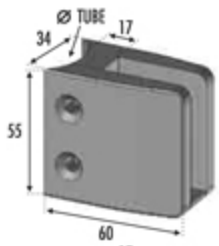

REF.	Ø DU TUBE	
IN2540	42,4	ZAMAC BRUT

REF.	FIXATION	
IN2541	PLAT	ZAMAC BRUT

REF.	Ø DU TUBE	
IN2542	42,4	ZAMAC BROSSÉ

REF.	FIXATION	
IN2543	PLAT	ZAMAC BROSSÉ

REF.	Ø DU TUBE	
IN2544	42,4	INOX 316

REF.	FIXATION	
IN2545	PLAT	INOX 316

CAOUTCHOUC À COMMANDER

POUR VERRE DE 8 À 12,76, CHAQUE PINCE À VERRE EST LIVRÉE AVEC SES VIS DE FIXATION.



REF.	VERRE	
IN2550	8	
IN2551	8,76	44,2
IN2552	10	
IN2553	10,76	55,2
IN2554	12	
IN2555	12,76	66,2

PINCES À VERRE CARRÉES 45 mm

CAOUTCHOUC À COMMANDER / LIVRÉE AVEC SES VIS DE FIXATION 6 X 20

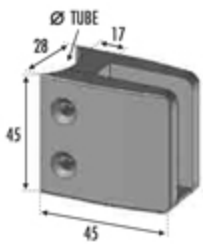

REF.	Ø DU TUBE	
IN2560	42,4	INOX 316

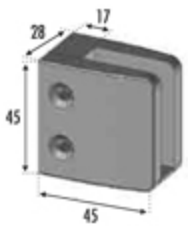

REF.	FIXATION	
IN2561	PLAT	INOX 316

☎ CAOUTCHOUC À COMMANDER



REF.	VERRE
IN2565	8,76

PINCES À VERRE RONDES 64 mm

CAOUTCHOUC À COMMANDER EN FONCTION DE VOTRE ÉPAISSEUR DE VERRE / LIVRÉE AVEC SES VIS DE FIXATION 8 X 20

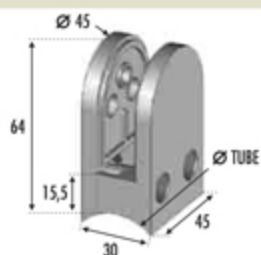

REF.	Ø DU TUBE	
IN2570	42,4	ZAMAC BRUT
IN2571	48,3	ZAMAC BRUT

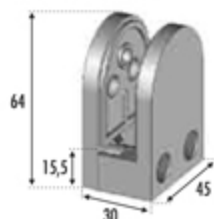

REF.	FIXATION	
IN2572	PLAT	ZAMAC BRUT

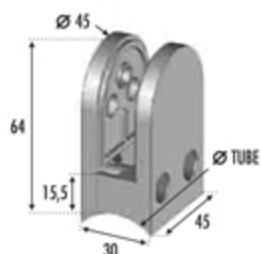

REF.	Ø DU TUBE	
IN2573	42,4	ZAMAC BROSSÉ
IN2574	48,3	ZAMAC BROSSÉ

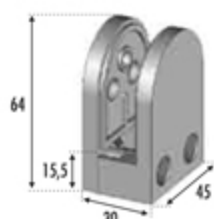

REF.	FIXATION	
IN2575	PLAT	ZAMAC BROSSÉ

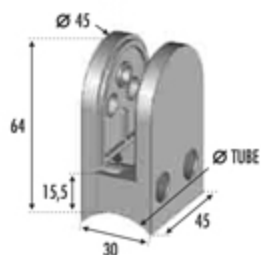

REF.	Ø DU TUBE	
IN2576	42,4	INOX 316 BROSSÉ
IN2577	48,3	INOX 316 BROSSÉ

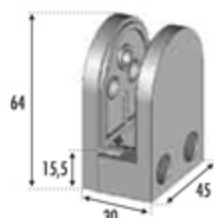

REF.	FIXATION	
IN2578	PLAT	INOX 316 BROSSÉ

CAOUTCHOUC À COMMANDER

POUR VERRE DE 8 À 12,76,
CHAQUE PINCE À VERRE EST LIVRÉE AVEC
SES VIS DE FIXATION ET SON PIN SÉCURITÉ.



REF.	VERRE	
IN2585	8	
IN2586	8,76	44,2
IN2587	10	
IN2588	10,76	55,2
IN2589	12	
IN2590	12,76	66,2

PINCES À VERRE RONDES 41 mm

CAOUTCHOUC À COMMANDER / LIVRÉE AVEC SES VIS DE FIXATION 6 X 20



POUR TUBE

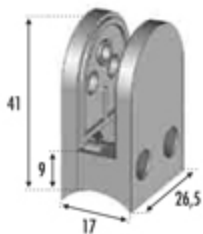

POUR PLAT

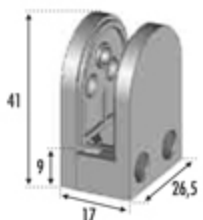

POUR TUBE



POUR PLAT



	REF.	Ø DU TUBE	
	IN2595	18	ZAMAC BRUT
NOUVEAU	IN2596	42,4	ZAMAC BRUT
	IN2598	PLAT	ZAMAC BRUT

	REF.	Ø DU TUBE	
	IN2599	18	ZAMAC BROSSÉ
NOUVEAU	IN2600	42,4	ZAMAC BROSSÉ
	IN2602	PLAT	ZAMAC BROSSÉ

	REF.	Ø DU TUBE	
	IN2603	18	INOX 316 BROSSÉ
NOUVEAU	IN2604	42,4	INOX 316 BROSSÉ
	IN2606	PLAT	INOX 316 BROSSÉ

☎ CAOUTCHOUC À COMMANDER



REF.	VERRE
IN2610	8,76

PINCES À VERRE EN APPLIQUE INOX 316

CAOUTCHOUC À COMMANDER EN FONCTION DE VOTRE ÉPAISSEUR DE VERRE / LIVRÉE AVEC SES VIS DE FIXATION 8 X 20

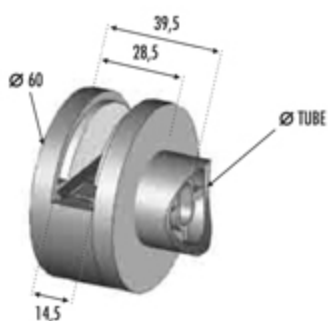

REF.	Ø DU TUBE	
IN2615	42,4	INOX 316 BROSSÉ
IN2616	48,3	INOX 316 BROSSÉ

REF.	FIXATION	
IN2617	PLAT	INOX 316 BROSSÉ

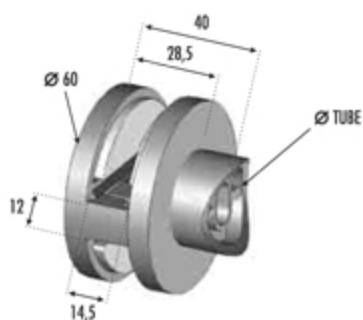

REF.	Ø DU TUBE	
IN2618	42,4	INOX 316 BROSSÉ
IN2619	48,3	INOX 316 BROSSÉ

REF.	FIXATION	
IN2620	PLAT	INOX 316 BROSSÉ

CAOUTCHOUC À COMMANDER

POUR VERRE DE 8 À 12,76, CHAQUE PINCE À VERRE EST LIVRÉE AVEC SES VIS DE FIXATION.



REF.	VERRE	
IN2621	8	
IN2622	8,76	44,2
IN2623	10	
IN2624	10,76	55,2
IN2625	12	
IN2626	12,76	66,2

GARDE CORPS VERRE



REF.	VERRE	
IN2627	12,76	INOX 316 BROSSÉ

VERRE PRÊT À POSER / JOINT POLI

REF.	DIMENSION	FEUILLETÉ
IN2628	450 X 1000	8,76
IN2629	1000 X 1000	12,76

Le verre feuilleté est composé de 2 feuilles de verre séparées par un intercalaire en PVB. Il peut être brisé mais les fragments restent collés. La vitre reste en un seul morceau.

UTILISATION RECOMMANDÉE POUR LES GARDES CORPS.



GARDES CORPS EN VERRE 12,76 / FIXATION À L'ANGLAISE

VERRE DISPONIBLE P. 37

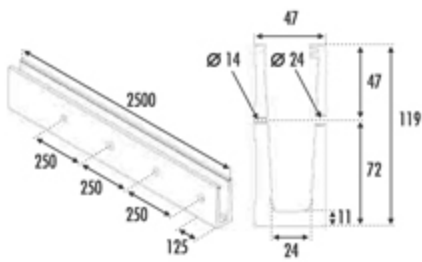

REF.	LONGUEUR	
IN2635	2 500	ALUMINIUM BROSSÉ

Un jeu permet la pose de 2500 mm de rail aluminium réf. 30850

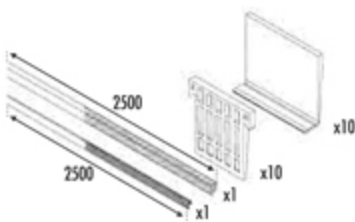

REF.	VERRE	LONGUEUR
IN2637	12,76	2 500

Finition latérale INOX 316 / À utiliser aux terminaisons sans le revêtement frontal

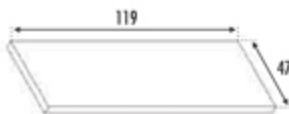

REF.	ÉPAISSEUR	INOX 316
IN2638	1,5	

Revêtement de finition frontale INOX 316

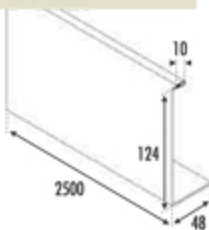

REF.	LONGUEUR	ÉPAISSEUR	INOX 316
IN2639	2 500	1,5	

Finition latérale INOX 316 / À utiliser avec le revêtement de finition frontal

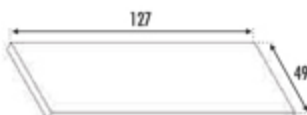

REF.	ÉPAISSEUR	INOX 316
IN2640	1,5	

GARDES CORPS EN VERRE 12,76 / FIXATION SOL

VERRE DISPONIBLE P. 37

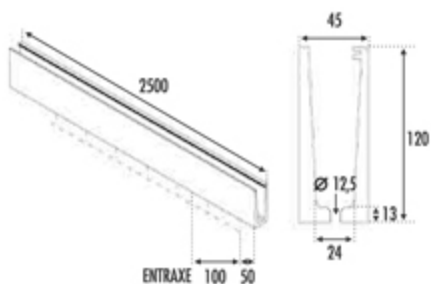

REF.	LONGUEUR	
IN2645	2 500	ALUMINIUM BROSSÉ

Un jeu permet la pose de 2500 mm de rail aluminium réf. 30855

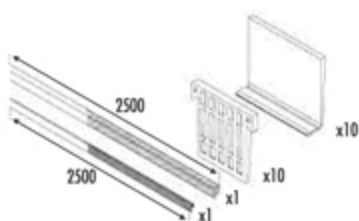

REF.	VERRE	LONGUEUR
IN2637	12,76	2 500

Finition latéral INOX 316 / À utiliser aux terminaisons sans le revêtement frontal



REF.	ÉPAISSEUR	INOX 316
IN2648	1,5	

Revêtement de finition frontal INOX 316



REF.	LONGUEUR	ÉPAISSEUR	INOX 316
IN2649	2 500	1,5	

Revêtement de finition arrière INOX 316

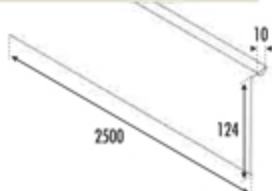

REF.	LONGUEUR	ÉPAISSEUR	INOX 316
IN2650	2 500	1,5	

Finition latéral INOX 316 / À utiliser avec les revêtements frontaux et arrière

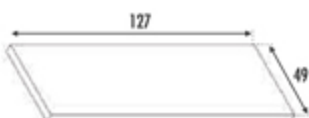

REF.	ÉPAISSEUR	INOX 316
IN2640	1,5	

GARDES CORPS EN VERRE 12,76 / MAINS COURANTES

VERRE DISPONIBLE P. 37

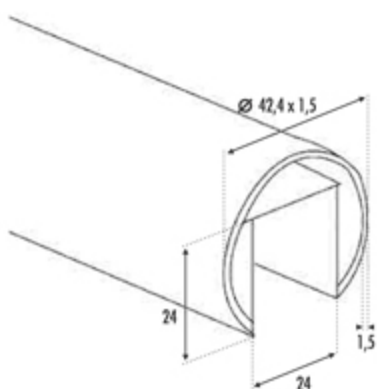

REF.	LONGUEUR	
IN2655	2 500	INOX 304

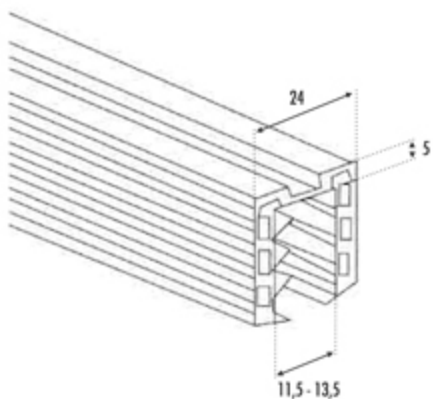

REF.	LONGUEUR	
IN2656	2 500	CAOUTCHOUC

GARDES CORPS EN VERRE 12,76 / MAINS COURANTES

VERRE DISPONIBLE P. 37



REF.	VERRE	
IN2657	12,76	INOX 304

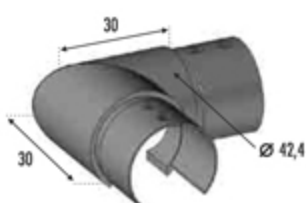

REF.	VERRE	
IN2658	12,76	INOX 304

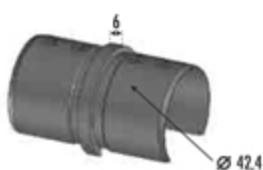

REF.	VERRE	
IN2659	12,76	INOX 304

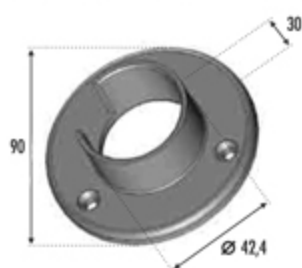

REF.	VERRE	
IN2660	12,76	INOX 304

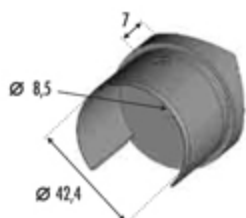

REF.	VERRE	
IN2661	12,76	INOX 304

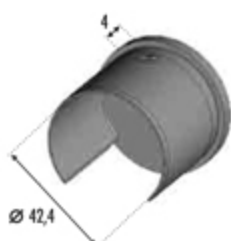

REF.	VERRE	
IN2662	12,76	INOX 304

EXEMPLES DE RÉALISATIONS



CÂBLES INOX 316



7 X 19
BRINS
INOX 316

REF.	Ø CÂBLE	LIVRAISON	
IN2665	4 mm	AU MÈTRE	INOX 316
IN2666	6 mm	AU MÈTRE	INOX 316

ANNEAUX DE BLOCAGE DE CÂBLES



REF.	Ø CÂBLE	VIS	D	L	
IN2668	4 mm	M 3	15	10	INOX 304
IN2669	6 mm	M 4	20	10	INOX 304

ANNEAUX ET BLOQUE CÂBLE

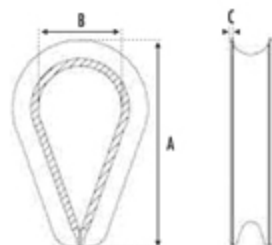
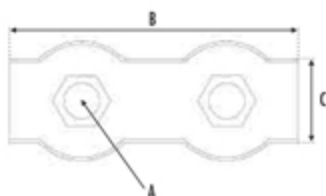

REF.	Ø CÂBLE	A	B	C	
IN2670	4 mm	8	40	12	INOX 316
IN2671	6 mm	10	60	16	INOX 316

REF.	Ø CÂBLE	A	B	C	
IN2672	4 mm	33	13	1,2	INOX 316
IN2673	6 mm	40	17	1,5	INOX 316

Exemple d'assemblage d'un ensemble de tendeurs pour garde-corps horizontal **SANS SERTISSAGE**

GARDE CORPS DROIT

PAS DE GAUCHE

PAS DE DROITE

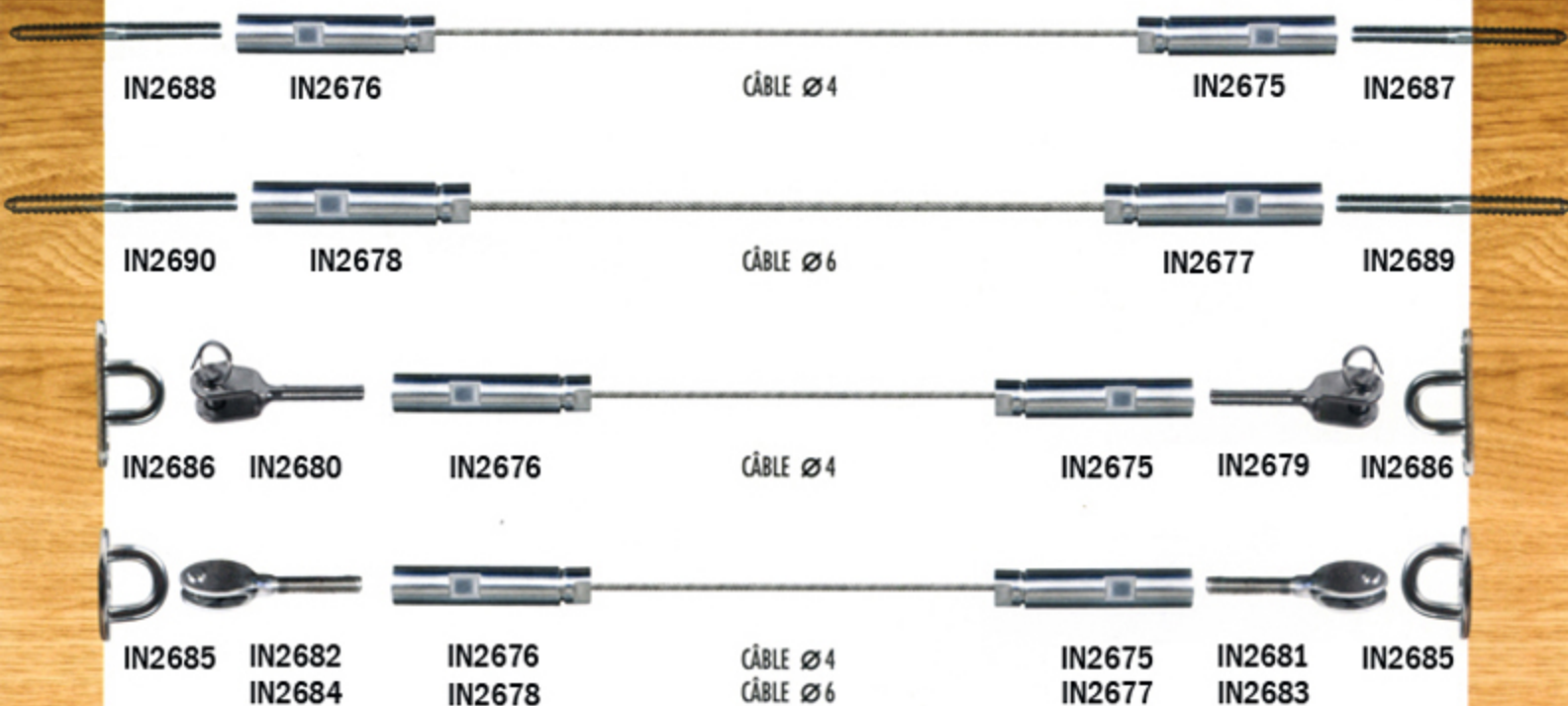

GARDE CORPS RAMPANT

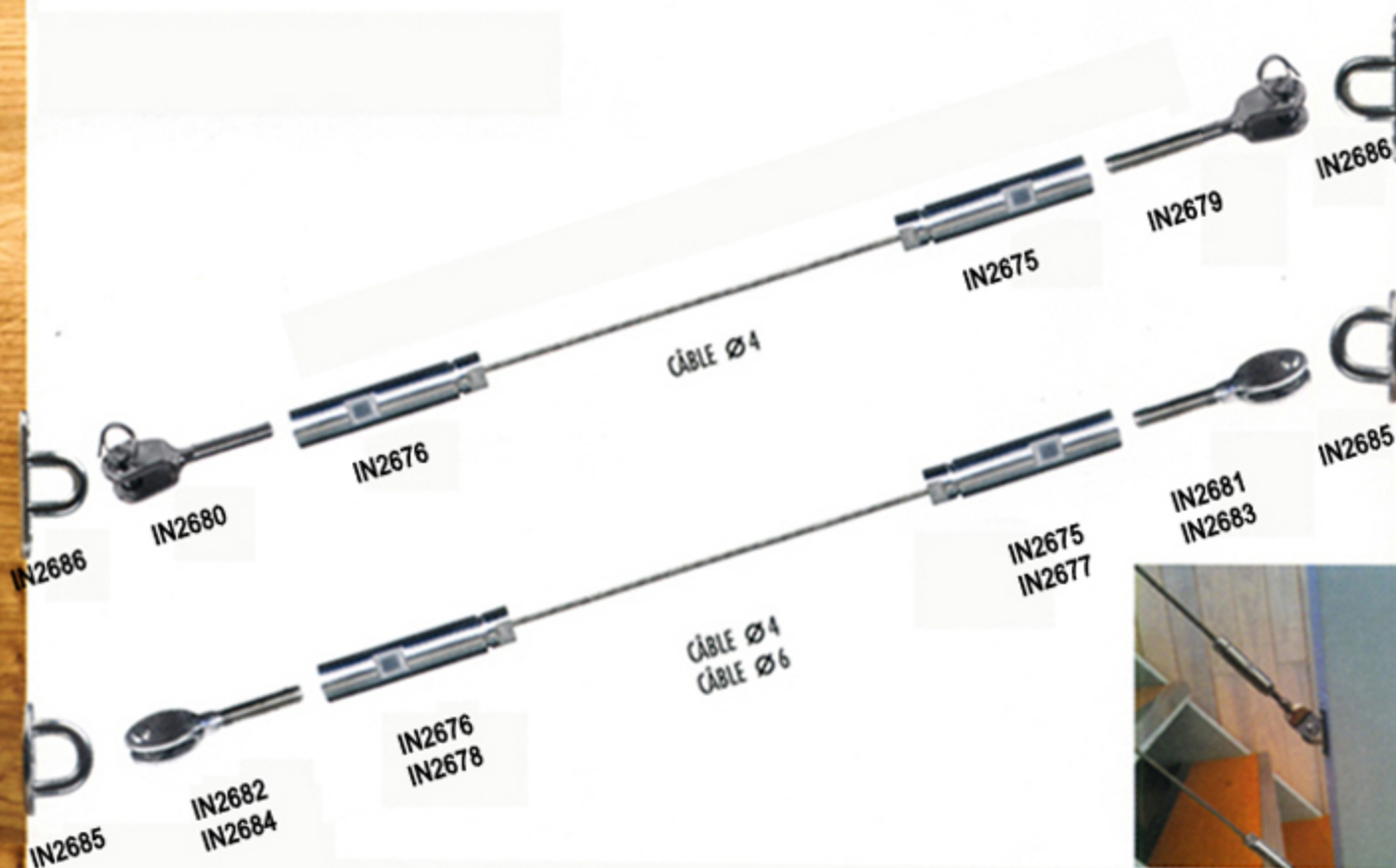

TENDEURS CÂBLE BLOCAGE MANUEL

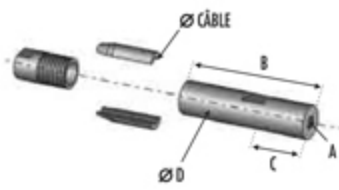

REF.	Ø CÂBLE	A	B	C	Ø D	
IN2675 PAS À DROITE	4 mm	M 6	44	18	11	INOX 316
IN2676 PAS À GAUCHE	4 mm	M 6	44	18	11	INOX 316
IN2677 PAS À DROITE	6 mm	M 8	55	20	15	INOX 316
IN2678 PAS À GAUCHE	6 mm	M 8	55	20	15	INOX 316

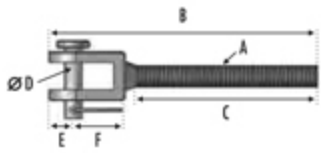

REF.	A	B	C	E	F	Ø D	H	
IN2679 PAS À DROITE	M 6	73	47	6	12	7,5	12,5	INOX 316
IN2680 PAS À GAUCHE	M 6	73	47	6	12	7,5	12,5	INOX 316

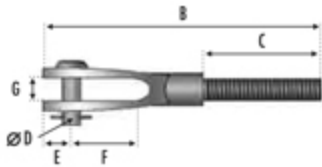

REF.	A	B	C	Ø D	E	F	G	H	
IN2681 PAS À DROITE	M 6	77	40	6	7,5	14	6,5	18	INOX 316
IN2682 PAS À GAUCHE	M 6	77	40	6	7,5	14	6,5	18	INOX 316
IN2683 PAS À DROITE	M 8	77	40	6	7,5	14	6,5	18	INOX 316
IN2684 PAS À GAUCHE	M 8	77	40	6	7,5	14	6,5	18	INOX 316

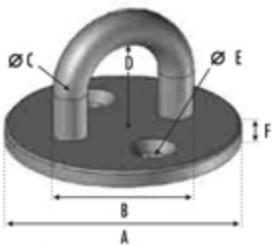

REF.	A	B	Ø C	D	Ø E	F	
IN2685	40	30	5	18	4,5	3	INOX 316

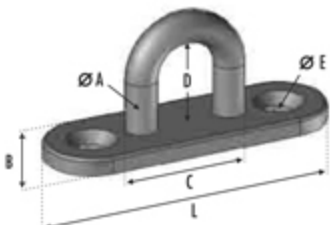

REF.	Ø A	B	C	D	Ø E	L	
IN2686	5	15	20	13	4,5	45	INOX 316

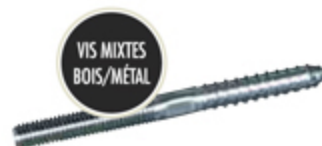
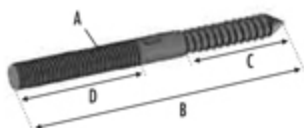

REF.	A	B	C	D	
IN2687 PAS À DROITE	M 6	80	40	30	INOX 316
IN2688 PAS À GAUCHE	M 6	80	40	30	INOX 316
IN2689 PAS À DROITE	M 8	90	60	40	INOX 316
IN2690 PAS À GAUCHE	M 8	90	60	40	INOX 316

Exemple d'assemblage d'un ensemble de tendeurs

pour garde-corps horizontal câble inox placé entre deux poteaux inox

SANS SERTISSAGE GARDE CORPS DROIT

PAS DE GAUCHE

PAS DE DROITE

PERÇAGE Ø 9 M 6
PERÇAGE Ø 11 M 8

M 6 PERÇAGE Ø 9
M 8 PERÇAGE Ø 11

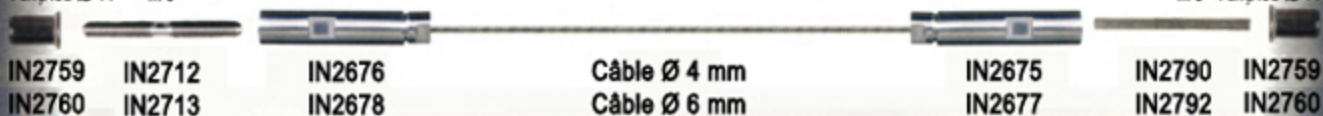

TENDEUR EN APPLIQUE

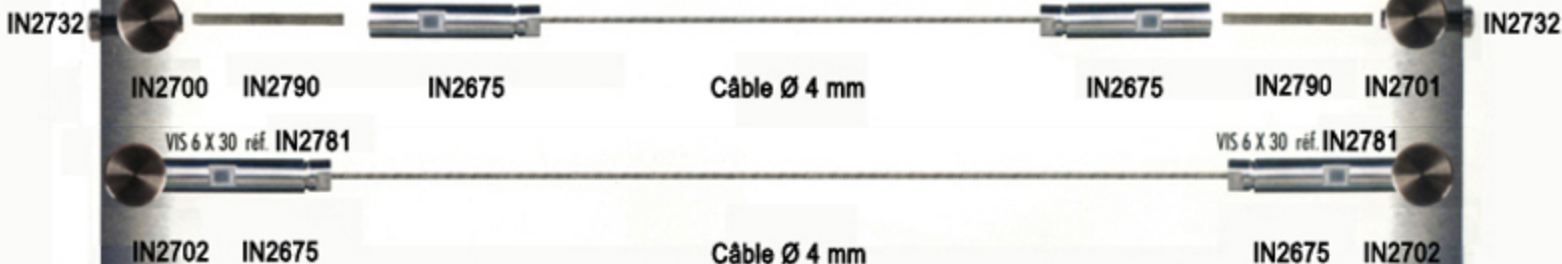

GARDE CORPS RAMPANT

PAS DE GAUCHE

PAS DE DROITE

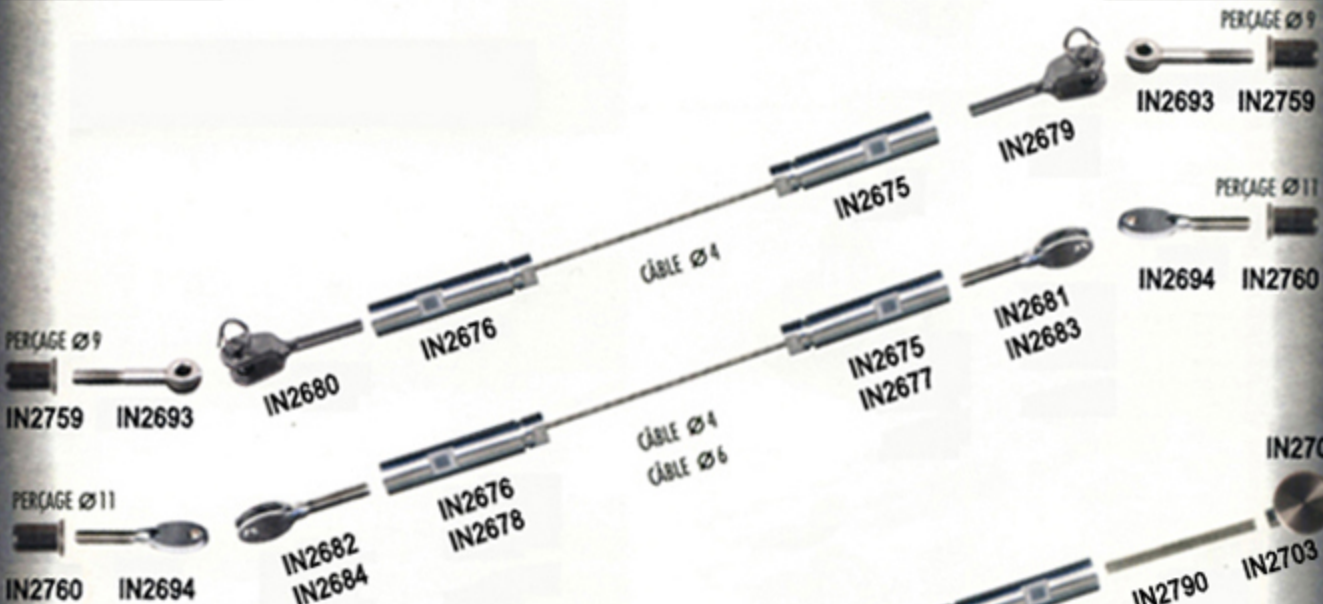

TENDEUR EN APPLIQUE

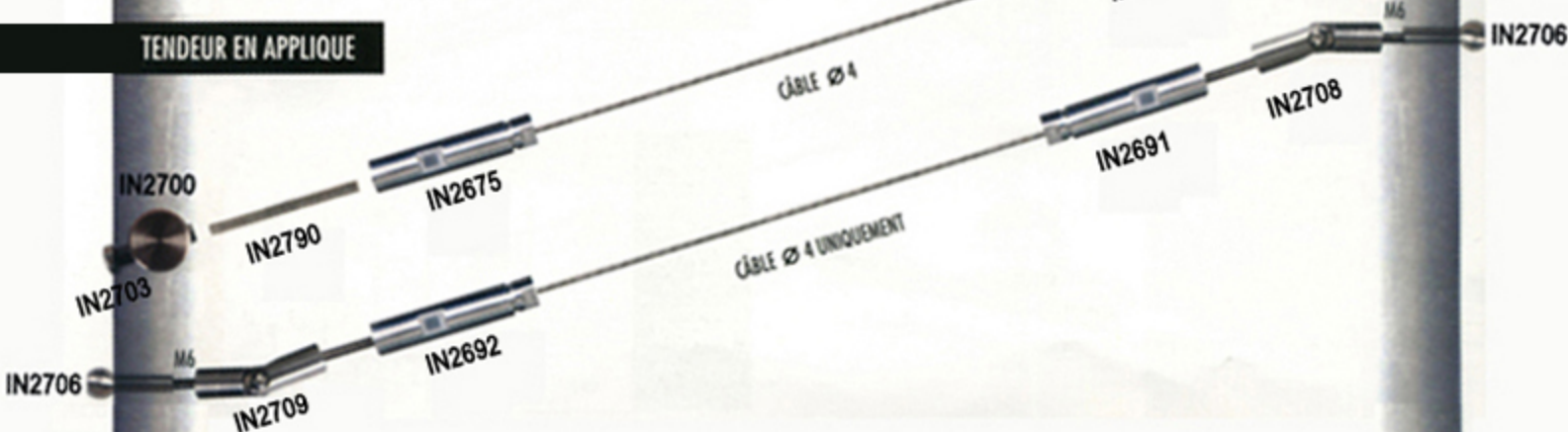

TENDEURS CÂBLE BLOCAGE MANUEL

SÉLECTION POUR MONTAGE POTEAUX MÉTALLIQUES

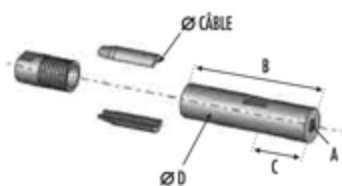

REF.	Ø CÂBLE	A	B	C	Ø D	
IN2675 PAS À DROITE	4 mm	M 6	44	18	11	INOX 316
IN2676 PAS À GAUCHE	4 mm	M 6	44	18	11	INOX 316
IN2677 PAS À DROITE	6 mm	M 8	55	20	15	INOX 316
IN2678 PAS À GAUCHE	6 mm	M 8	55	20	15	INOX 316

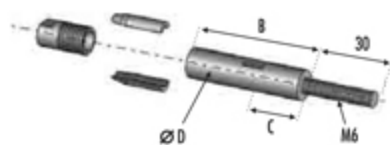

REF.	Ø CÂBLE	B	C	Ø D	
IN2691 PAS À DROITE	4 mm	44	18	11	INOX 316
IN2692 PAS À GAUCHE	4 mm	44	18	11	INOX 316

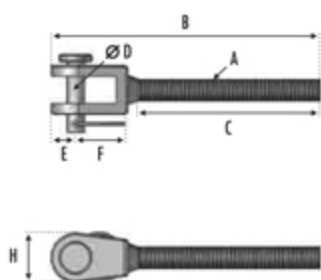

REF.	A	B	C	E	F	Ø D	H	
IN2679 PAS À DROITE	M 6	73	47	6	12	7,5	12,5	INOX 316
IN2680 PAS À GAUCHE	M 6	73	47	6	12	7,5	12,5	INOX 316

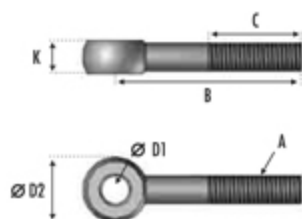

REF.	A	B	C	Ø D1	Ø D2	K	
IN2693 PAS À DROITE	M 6	40	20	6,4	14	7	INOX 316

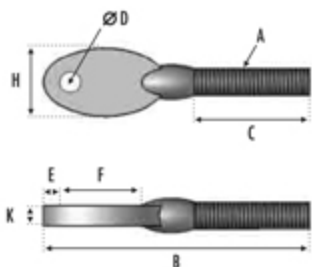

REF.	A	B	C	Ø D	E	F	H	K	
IN2694 PAS À DROITE	M 8	78	32	6	8	19	20	6	INOX 316

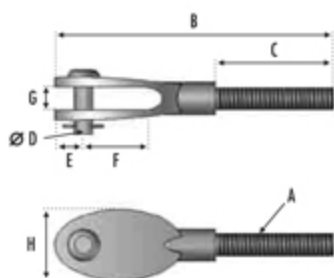

REF.	A	B	C	Ø D	E	F	G	H	
IN2681 PAS À DROITE	M 6	77	40	6	7,5	14	6,5	18	INOX 316
IN2682 PAS À GAUCHE	M 6	77	40	6	7,5	14	6,5	18	INOX 316
IN2683 PAS À DROITE	M 8	77	40	6	7,5	14	6,5	18	INOX 316
IN2684 PAS À GAUCHE	M 8	77	40	6	7,5	14	6,5	18	INOX 316

CONNECTEURS EN APPLIQUE POUR CÂBLE

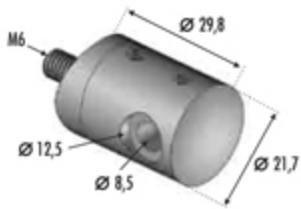

Exemple de montage avec IN2703

NOUVEAU	REF.	Ø TUBE	
	IN2700 DÉPART DROIT	42,4	INOX 316

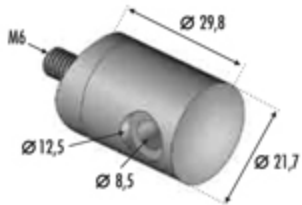

Exemple de montage avec IN2703

NOUVEAU	REF.	Ø TUBE	
	IN2701 DÉPART GAUCHE	42,4	INOX 316

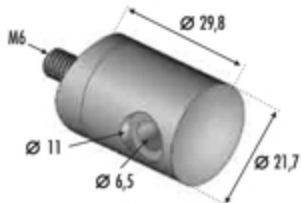

Exemple de montage avec IN2703

NOUVEAU	REF.	Ø TUBE	
	IN2702	42,4	INOX 316

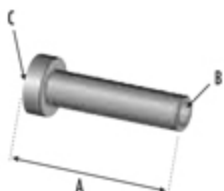

REF.	A	B	C	
IN2703	35	M 6	4	INOX 316
IN2704	40	M 8	5	INOX 316

CONNECTEURS EN APPLIQUE POUR CÂBLE

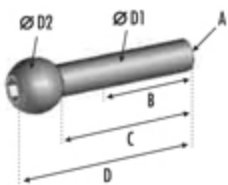

REF.	A	B	C	D	ØD1	ØD2	
IN2706	M 6	20	30	36,7	8	14	INOX 316
IN2707	M 8	28	30	36,7	10	18	INOX 316

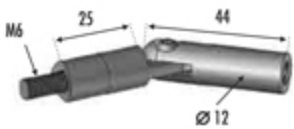

REF.	A	
IN2708 PAS À DROITE	M 6	INOX 316
IN2709 PAS À GAUCHE	M 6	INOX 316
IN2710 PAS À DROITE	M 8	INOX 316
IN2711 PAS À GAUCHE	M 8	INOX 316

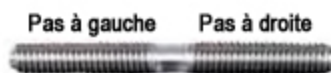
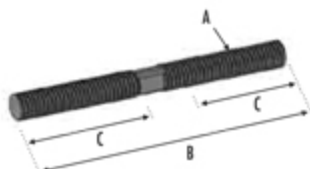

REF.	A	B	C	
IN2712	M 6	65	30	INOX 316
IN2713	M 8	65	30	INOX 316



REF.	A	EMBOUT	CONDITIONNEMENT	
IN2759	M 6	FILETÉ	SACHET DE 50 PIÈCES	ALUMINIUM
IN2760	M 8	FILETÉ	SACHET DE 50 PIÈCES	ALUMINIUM

Exemple d'assemblage d'un ensemble de tendeurs pour garde-corps droit câble inox placé entre deux poteaux inox ou un mur béton ou bois

AVEC SERTISSAGE

GARDE CORPS DROIT

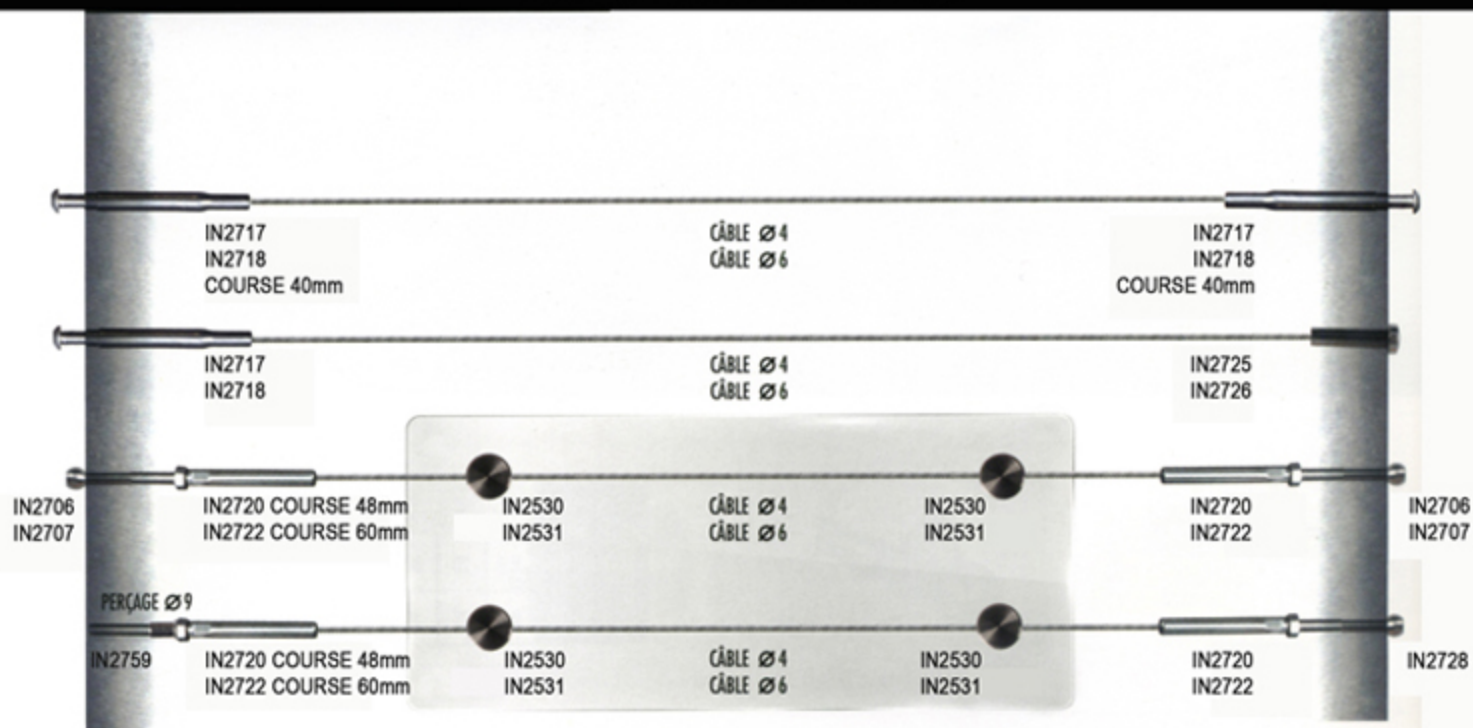

Béton ou bois



IN2730
IN2731

CÂBLE Ø 4
CÂBLE Ø 6

IN2717
IN2718
COURSE 40mm

Poteau



PINCE HYDRAULIQUE 16 TONNES
POUR SERTISSAGE SUR CHANTIER
CÂBLE 4 ET 6 mm

VOIR PAGE 54



TENDEURS À SERTIR CÂBLE 4 ET 6 mm

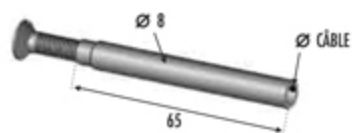

REF.	Ø CÂBLE	RÉGLAGE COURSE	
IN2717	4 mm	40 mm	INOX 316
IN2718	6 mm	40 mm	INOX 316



REF.	Ø CÂBLE	G	L	L1	L2	
IN2720 PAS À DROITE	4 mm	M 6	105	46	59	INOX 316
IN2721 PAS À GAUCHE	4 mm	M 6	105	46	59	INOX 316
IN2722 PAS À DROITE	6 mm	M 8	110	70	40	INOX 316
IN2723 PAS À GAUCHE	6 mm	M 8	110	70	40	INOX 316

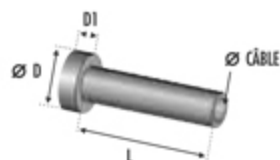

REF.	Ø CÂBLE	Ø D	D1	L	
IN2725	4 mm	10	2,5	32	INOX 316
IN2726	6 mm	14	5,5	30	INOX 316

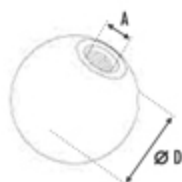

REF.	A	Ø D	
IN2728	M 6	15	INOX 316
IN2729	M 8	25	INOX 316

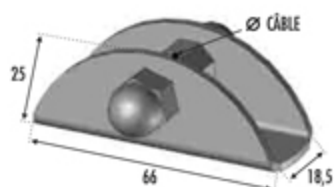

REF.	Ø CÂBLE	A	B	C	
IN2730	4 mm	25	66	18,5	INOX 304
IN2731	4 mm	25	66	18,5	INOX 304

Exemple d'assemblage d'un ensemble de tendeurs

pour garde-corps droit ou rampant câble inox placé entre deux poteaux inox

AVEC SERTISSAGE

GARDE CORPS DROIT OU RAMPANT

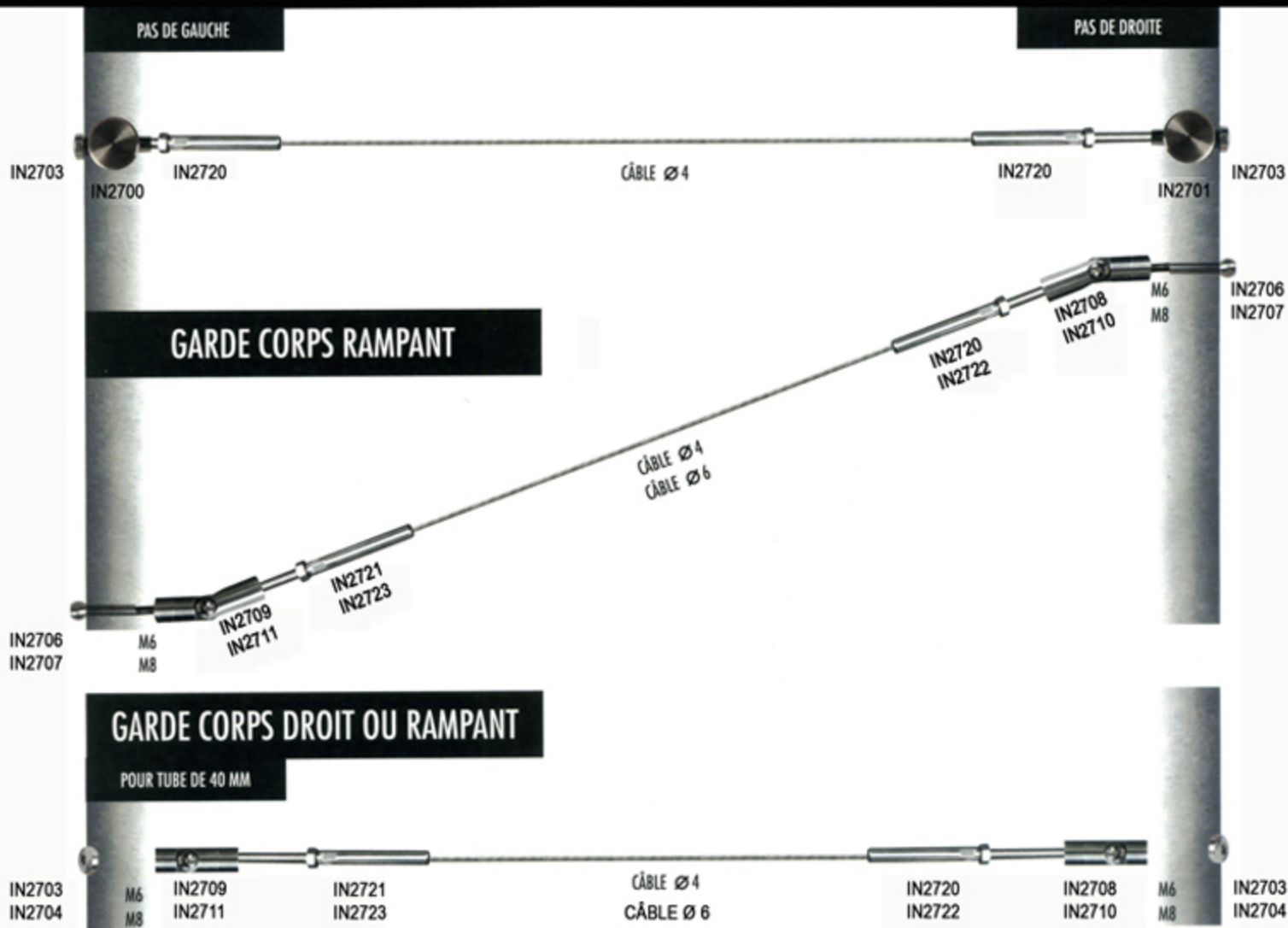

PINCE HYDRAULIQUE 16 TONNES
POUR SERTISSAGE SUR CHANTIER
CÂBLE 4 ET 6 mm
VOIR PAGE 54



TENDEURS À SERTIR CÂBLE 4 ET 6 mm

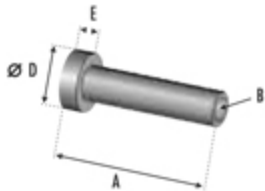

REF.	A	B	CLÉ	Ø D	E	
IN2703	35	M 6	4	12	4	INOX 316
IN2704	40	M 8	5	16	6	INOX 316

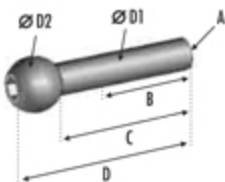

REF.	A	B	C	D	ØD1	ØD2	
IN2706	M 6	20	30	42	8	14	INOX 316
IN2707	M 8	28	40	56	10	18	INOX 316

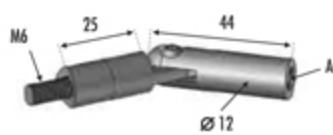

REF.	A	
IN2708 PAS À DROITE	M 6	INOX 316
IN2709 PAS À GAUCHE	M 6	INOX 316
IN2710 PAS À DROITE	M 8	INOX 316
IN2711 PAS À GAUCHE	M 8	INOX 316

OUTILLAGE



REF.	DESCRIPTION
IN2755	PINCE HYDRAULIQUE 16 TONNES LIVRÉES AVEC OUTILLAGE POUR SERTISSAGE TENDEURS SUR CÂBLE 4 ET 6 mm



REF.	DESCRIPTION
IN2756	COUPE INOX CÂBLE 4 ET 6 mm



REF.	DESCRIPTION
IN2757	POUR INSERT M6 ET M8



NOUVEAU	REF.	DESCRIPTION
	IN2758	CLÉ DE SERRAGE Ø 60



REF.	A	EMBOUT	CONDITIONNEMENT	
IN2759	M 6	FILETÉ	LOT DE 50 PIÈCES	ALUMINIUM
IN2760	M 8	FILETÉ	LOT DE 50 PIÈCES	ALUMINIUM

VISSERIE INOX A4



REF.	TARAUDEGE	
IN2765	M 6	INOX 316
IN2766	M 8	INOX 316
IN2767	M 6 PAS À GAUCHE	INOX 316
IN2768	M 8 PAS À GAUCHE	INOX 316
IN2769	M 12	INOX 316



REF.	TARAUDEGE	
IN2775	M 6	INOX 316
IN2776	M 8	INOX 316
IN2777	M 12	INOX 316



REF.	Ø x L	
IN2780	6 x 20	INOX 316
IN2781	6 x 30	INOX 316
IN2782	6 x 40	INOX 316
IN2783	8 x 30	INOX 316
IN2784	8 x 60	INOX 316



REF.	Ø x L	
IN2785	12 x 80	INOX 316



REF.	FILETAGE x L	
IN2790	M 6 x 50	INOX 316
IN2791 PAS À GAUCHE	M 6 GAUCHE x 50	INOX 316
IN2792	M 8 x 50	INOX 316
IN2793 PAS À GAUCHE	M 8 GAUCHE x 50	INOX 316
IN2794	M 12 x 170	INOX 316
IN2795	M 12 x 300	INOX 316
IN2796	M 12 x 1000	INOX 316

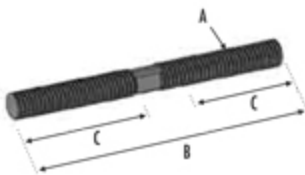

REF.	A	B	C	
IN2712	M 6	65	30	INOX 316
IN2713	M 8	65	30	INOX 316

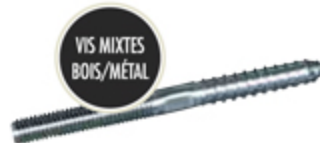
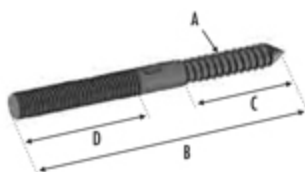

REF.	A	B	C	D	
IN2687 PAS À DROITE	M 6	80	40	30	INOX 316
IN2688 PAS À GAUCHE	M 6	80	40	30	INOX 316
IN2689 PAS À DROITE	M 8	90	60	40	INOX 316
IN2690 PAS À GAUCHE	M 8	90	60	40	INOX 316

COLLES ET ACCESSOIRES



REF.	DESCRIPTION
IN2800	KIT COMPLET COLLAGE INOX BICOMPOSANT



REF.	DESCRIPTION
IN2801	PISTOLET POUR CARTOUCHE PUISSANCE +



REF.	DESCRIPTION
IN2802	RECHARGE 50 ML COLLE BICOMPOSANT INOX



REF.	DESCRIPTION
IN2803	JEU DE 6 MÉLANGEURS POUR PISTOLET



REF.	DESCRIPTION
IN2804	NETTOYAGE AVANT COLLAGE



REF.	DESCRIPTION
IN2805	FREIN FILET FORT 50 ml

NETTOYAGE ET FINITION / ENTRETIEN DE L'INOX

RECOMMANDATIONS

Lors de la production de l'INOX, la présence de chrome à sa surface permet une protection contre l'oxydation.
Plus le chrome est présent, plus l'INOX sera résistant à la corrosion.

Il existe plusieurs types d'INOX.

L'ensemble de la gamme, présente dans ce catalogue, est de type 304 ou 316.

L'inox 304 est le plus couramment utilisé pour l'intérieur. Sa résistance à la corrosion est suffisante pour garantir un aspect durable dans le temps en environnement non agressif.

L'INOX 316 est plus riche en chrome, il sera plus résistant donc plus adapté aux exigences de l'extérieur et de milieux plus agressifs. Il est néanmoins conseillé dans des environnements agressifs (moins de 20 km de la mer, bord de piscine) de faire passer l'INOX.

ENTRETIEN

L'INOX n'est pas exempt d'entretien. Afin de prévenir son ternissement et l'apparition d'éventuel point d'oxydation, il est conseillé de l'entretenir périodiquement avec des produits adaptés.

Vous trouverez ci dessous notre gamme de produits spécifiques permettant un entretien facile.



REF.	DESCRIPTION
IN2810	DÉGRAISSAGE / PASSIVATION / NETTOYAGE APRÈS OXYDATION



REF.	DESCRIPTION
IN2813	GANTS DE PROTECTIONS ANTI ACIDE



REF.	DESCRIPTION
IN2811	GEL DÉCAPANT SOUDURE



REF.	DESCRIPTION
IN2814	PINCEAU SPÉCIAL ACIDE



REF.	DESCRIPTION
IN2812	FINITION SANS TRACE / ENTRETIEN ET PROTECTION



REF.	DESCRIPTION
IN2815	ABRASIF DE FINITION DOUX



REF.	DESCRIPTION
IN2816	ABRASIF DE FINITION FORT

