



11a

RAILS et ROULETTES

Accessoires de GUIDAGE

GATES ACCESSORIES/ACCESSORIOS DE PORTALES



SYSTÈME POUR PORTAIL AUTOPORTANT

CANTILEVER GATES SYSTEM / PUERTA CORREDERA AUTOPORTANTE

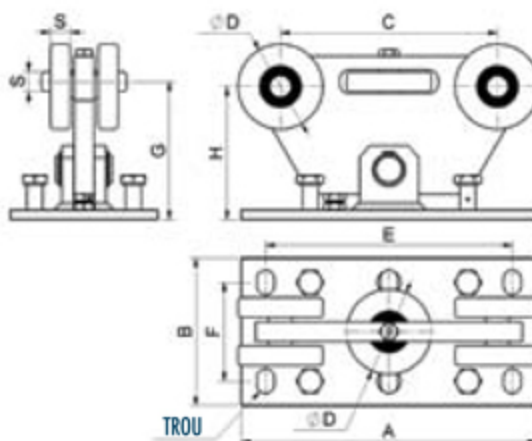

REF.	A	B	C	Ø D	E	F	G	H	S	TROU	P KG	OUVERTURE
FN36513	180	150	135	Ø 59,5	125	100	100	100	15	18 X 25	150 À 600 KG	DE 3 À 6 M
FN36714	300	150	220	Ø 86	250	100	140	135	20	18 X 25	300 À 750 KG	JUSQU'A 10 M

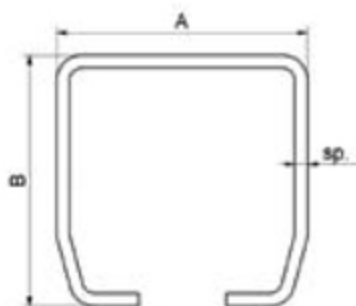

REF.	A	B	SP	LONGUEUR	
FN36515	67	67	3	3000	BRUT
FN36516	67	67	3	3000	ZINGUÉ

REF.	A	B	SP	LONGUEUR	
FN36517	98	98	5	3000	BRUT
FN36518	98	98	5	3000	ZINGUÉ

EXEMPLES DE MONTAGE SYSTÈME POUR PORTAIL AUTOPORTANT

EXEMPLE CANTILEVER GATES SYSTEM
EJEMPLO PUERTA CORREDERA AUTOPORTANTE

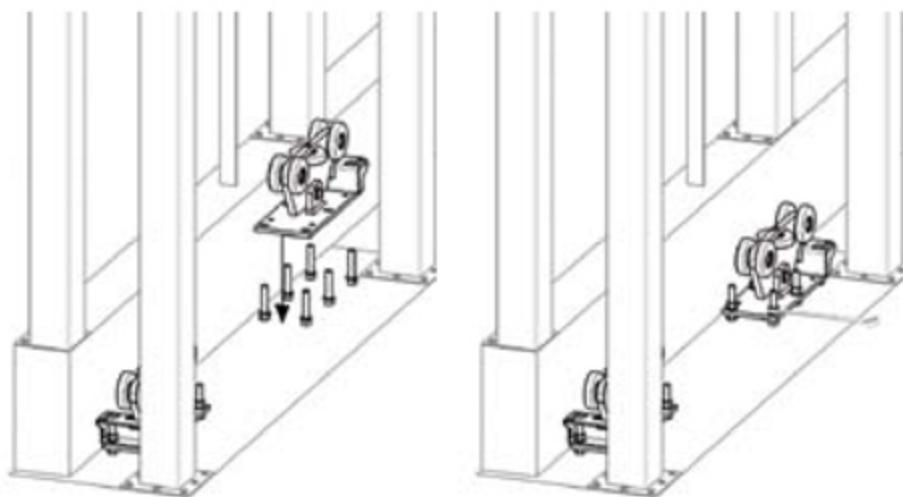

SYSTÈME POUR PORTAIL AUTOPORTANT

CANTILEVER GATES SYSTEM / PUERTA CORREDERA AUTOPORTANTE

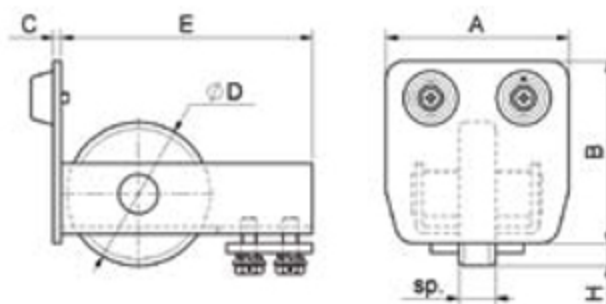

REF.	A	B	C	∅ D	E	H	SP
FN36491	67	67	4	∅ 67	120	14,5	15
FN36492	98	98	4	∅ 77	135	12	20

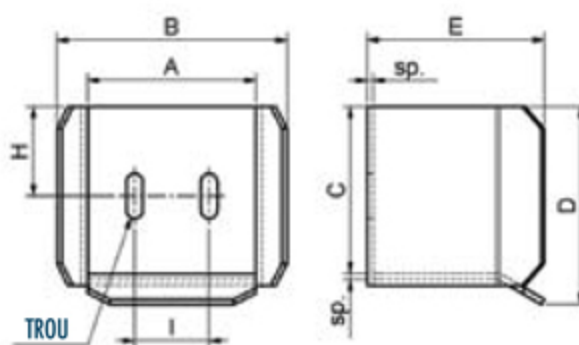

REF.	A	B	C	D	E	SP	I	H	TROU
FN36493	80	115	77	95	104	2,7	38	40	11 X 30
FN36494	113	154	112	133	119	4	50	60	11 X 30

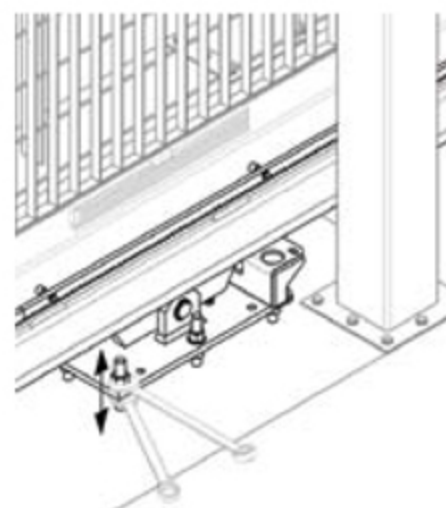
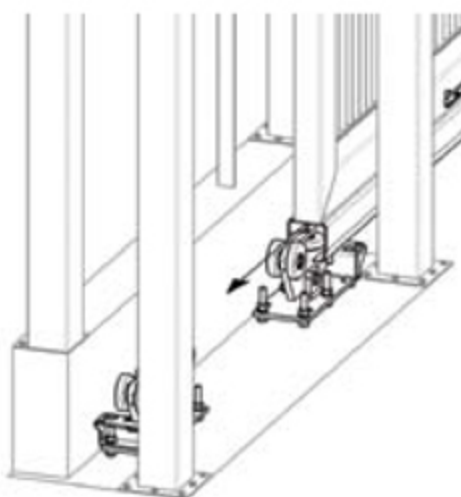
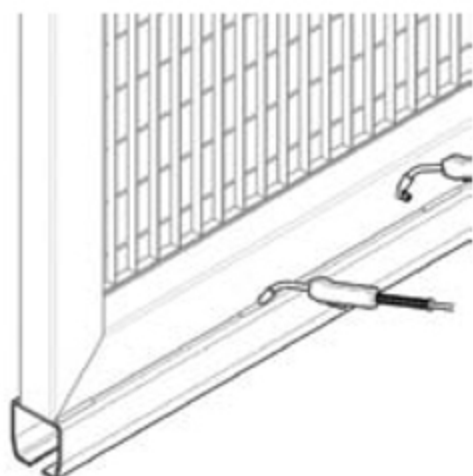



ROUE À GORGE TRIANGULAIRE

WHEEL WITH Y GROOVE / RUEDA CON CANAL Y

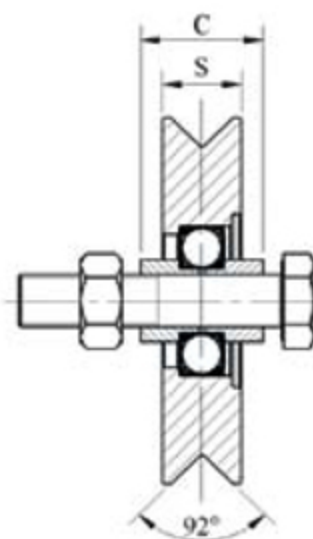

REF.	(Ø)	C	S	M	P KG
FN3620	60	22	20	M8 X 50	100
FN3621	80	30	20	M10 X 50	300
FN3622	100	30	21	M12 X 60	380
FN3623	120	34	24	M14 X 70	410
FN3624	140	44	25	M16 X 70	450
FN3625	160	44	25	M16 X 70	550
FN3626	200	44	25	M16 X 70	600
INOX FN36261	100	34	21	M14 X 70	380
INOX FN36262	120	34	24	M14 X 70	410

ROUE À GORGE RONDE

WHEEL WITH U GROOVE / RUEDA CON CANAL U

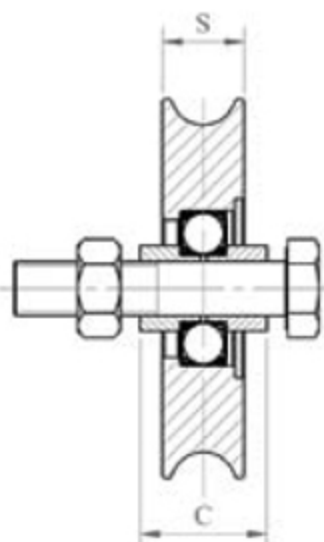

REF.	(Ø)	RAIL	C	S	M	P KG
FN3627	60	Ø 16	24	17	M10 X 50	100
FN3628	80	Ø 16	30	20	M12 X 50	300
FN3629	100	Ø 16	30	21	M12 X 60	380
FN3630	120	Ø 20	34	24	M14 X 70	410
FN3631	140	Ø 20	44	25	M16 X 70	450
FN3632	160	Ø 20	44	25	M16 X 70	550
FN3633	200	Ø 20	44	25	M16 X 70	600
INOX FN36331	100	Ø 20	34	21	M14 X 70	380
INOX FN36332	120	Ø 20	34	24	M14 X 70	410

ROUE À GORGE RONDE

WHEEL WITH U GROOVE / RUEDA CON CANAL U

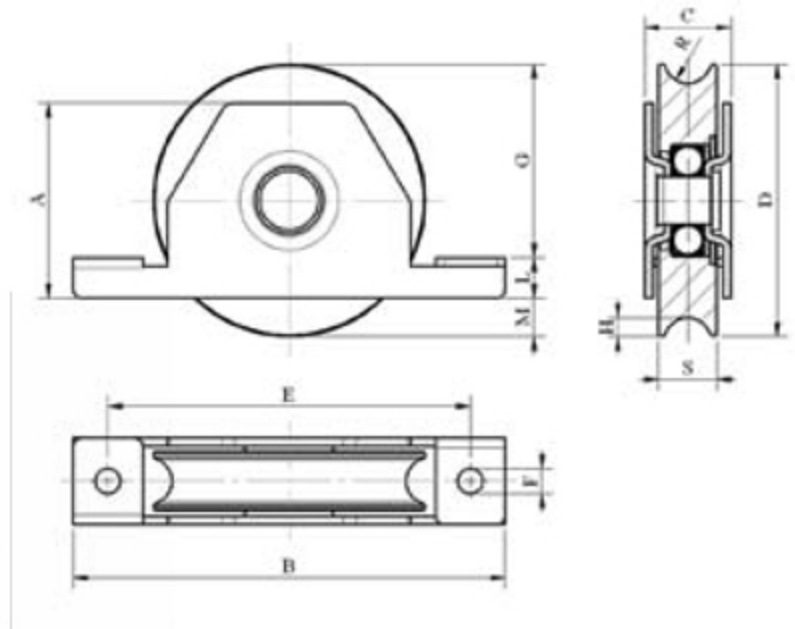

NOUVEAU
BANDAGE NYLON

DOUBLE ROULEMENT

NOUVEAU
DOUBLE ROULEMENT

NOUVEAU
DOUBLE ROULEMENT

INOX

NOUVEAU
DOUBLE ROULEMENT

REF.	(Ø)	RAIL	B	C	E	F	G	L	M	S	P KG
FN3638	50	16	95	26	75	∅ 7	34	8	8	17	100
FN3639	80	16	135	29	110	∅ 9	49,5	14	14	20	200
FN36391	80	16	135	29	110	∅ 9	49,5	14	14	20	200
FN3640	100	16	155	32	130	∅ 9	69	14,5	14	21	230
FN3641	120	20	185	42	155	∅ 9	85,5	15	17	24	450
FN3642	140	20	200	43	170	∅ 9	105	16	18	30	500
FN36392	160	20	225	43	194	∅ 10	116	19	25	30	550
FN36381	50	16	95	26	75	∅ 7	34	8	8	17	100
FN36421	80	16	135	29	110	∅ 9	49,5	14	14	20	200
FN36422	100	16	155	32	130	∅ 9	69	14,5	14	21	230
FN36424	120	20	200	43	169	∅ 9	90	15	16	30	500



ROUE À SUPPORT À ENCASTRER

WHEEL WITH CLOSED BRACKET / RUEDA CON SOPORTE CERRADO

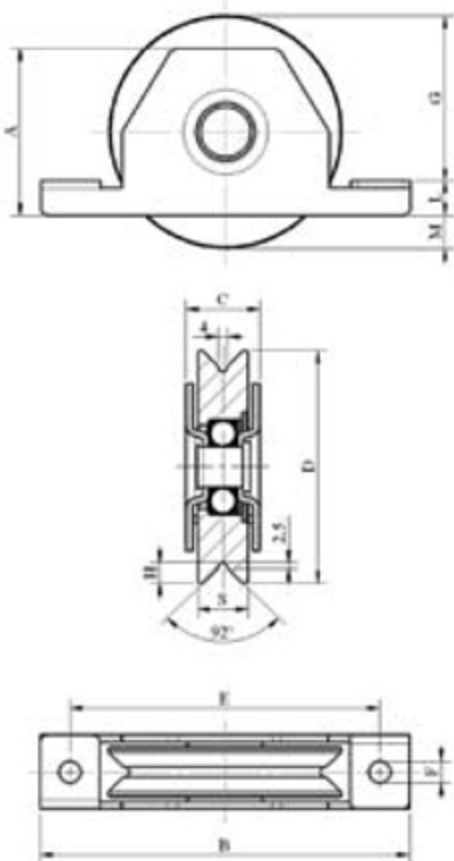

		GORGE TRIANGULAIRE									
	REF.	(∅)	B	C	E	F	G	L	M	S	PKG
NOUVEAU	FN36339	50	95	25	75	∅7	49,5	14	14	20	100
	FN3634	80	135	32	110	∅9	49,5	14	14	21	230
	FN3635	100	155	32	130	∅9	69	14,5	14	21	230
DOUBLE ROULEMENT	FN3636	120	185	42	155	∅9	85,5	15	17	24	450
	FN3637	140	205	34	175	∅11	105	17	15,5	25	300
INOX	FN36371	100	155	32	130	∅9	69	14,5	14	21	230
	FN36372	120	185	34	155	∅9	85,5	15	17	24	250

ROUE À SUPPORT À VISSER

WHEEL WITH FIXED / RUEDA CON SOPORTE

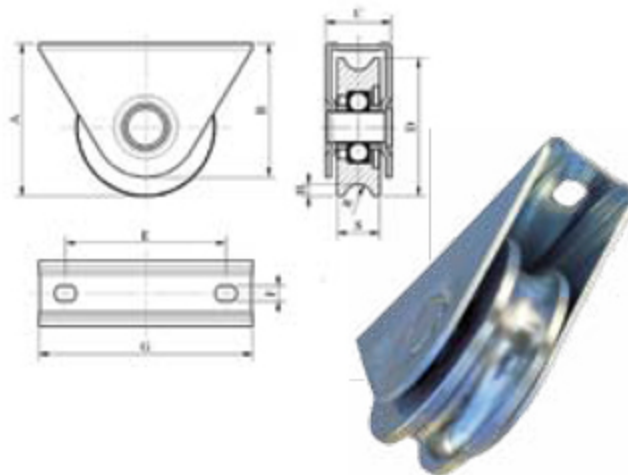
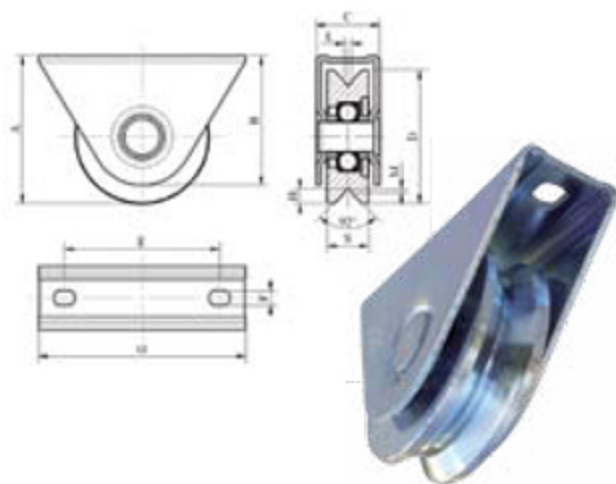

GORGE TRIANGULAIRE								
REF.	(∅)	A	C	E	F	G	S	PKG
FN3643	60	64	28	90	8,5X12	85	24	150
FN3644	80	86	37	90	8,5X12	120	24	200

GORGE RONDE										
REF.	(∅)	RAIL	A	C	E	F	G	S	R	PKG
FN3645	60	∅16	64	28	90	8,5X12	85	24	8,3	150
FN3646	80	∅16	86	37	90	8,5X12	120	24	8,3	200



RAIL À VISSER GORGE RONDE

SCREW RAIL U GROOVE / RAIL TORNILLO CANAL U

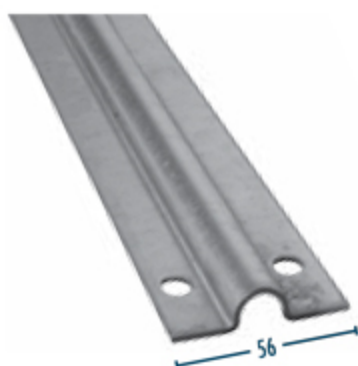

FN3660

L 2000

∅ 16

ÉPAISSEUR 2,5

FN3661

L 3000

∅ 16

ÉPAISSEUR 3

FN3662

L 3000

∅ 20

ÉPAISSEUR 3

RAIL À VISSER GORGE RONDE INOX

SCREW RAIL U GROOVE / RAIL TORNILLO CANAL U

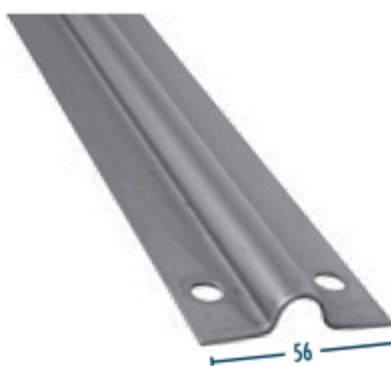

FN3666

L 3000

INOX

∅ 16

ÉPAISSEUR 3

FN3667

L 3000

NOUVEAU
INOX

∅ 20

ÉPAISSEUR 3

RAIL À VISSER TRIANGULAIRE

SCREW RAIL Y GROOVE / RAIL TORNILLO CANAL Y



FN3663

L 3000

NOUVEAU

ÉPAISSEUR 2,5

RAIL À SCELLER GORGE RONDE

SEAL RAIL U GROOVE / RAIL SELLAR CANAL U



FN3664

H 50 X 40
L 3000

∅ 16

ÉPAISSEUR 3

FN3659

H 65 X 50
L 3000

∅ 20

ÉPAISSEUR 3



AVALOIRS

AVALOIRS / AVALOIRS

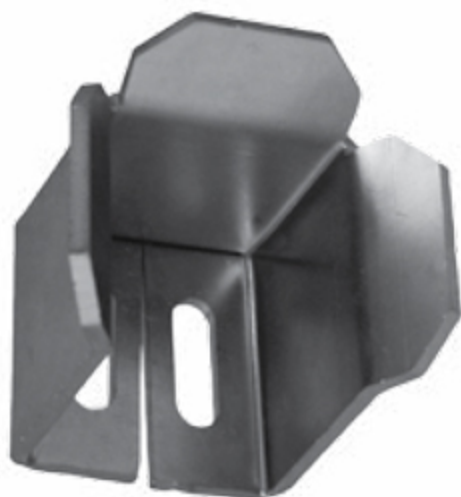

FN34921
POUR TUBE ■ 40

FN34922
POUR TUBE ■ 50

FN34923
POUR TUBE ■ 60

BUTÉES D'ARRÊT

GATE STOP / TOPE DE PARADA

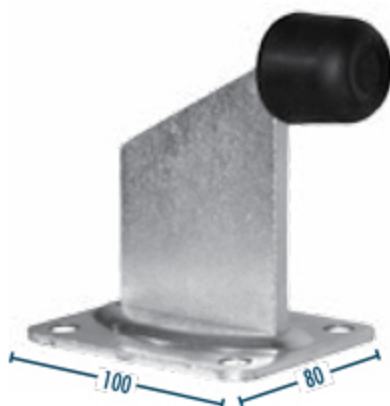

FN3491
H 93,5



FN3490
H 92,5

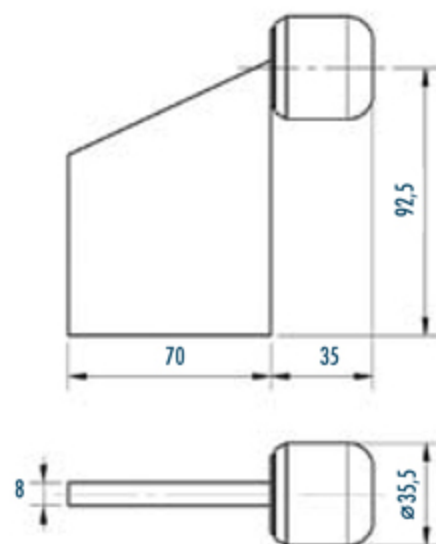

OLIVES DE GUIDAGE ET ACCESSOIRES

ROLLER TOP GUIDE AND NYLON / RODILLOS DE NYLON

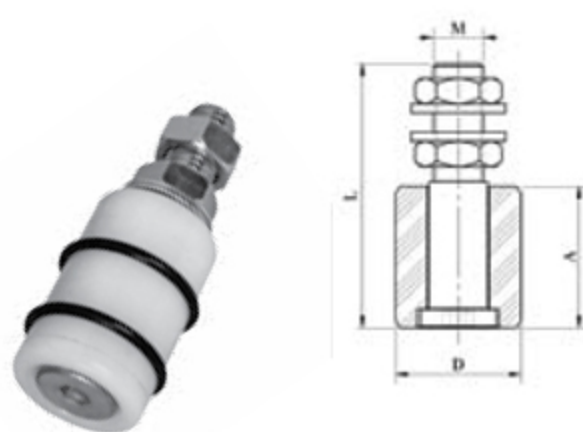
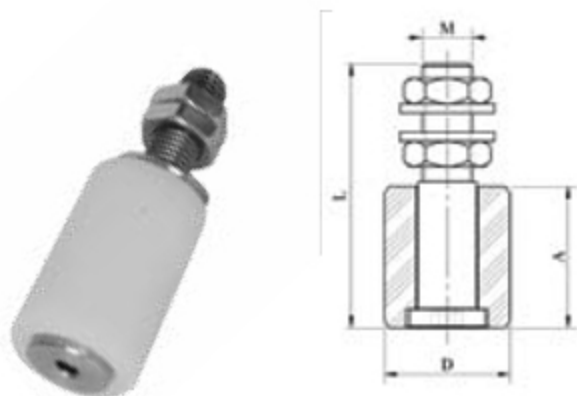

REF.	A	D (∅)	L	M
FN3652	40	25	75	12
FN3653	40,5	30	75	12
FN3654	59	40	99	16
INOX FN3656	40	30	77	14
INOX FN3657	45	40	85	16
NOUVEAU INOX FN3658	60	40	150	16

REF.	A	D (∅)	L	M
FN36541	40	30	75	12
FN36542	60	40	99	16



REF.	A	D (∅)	L	M
FN36543	40	30	75	12
FN36544	60	40	99	16

FN36545
M 14

∅ 35



OLIVES DE GUIDAGE ET ACCESSOIRES

ROLLER TOP GUIDE AND NYLON / RODILLOS DE NYLON

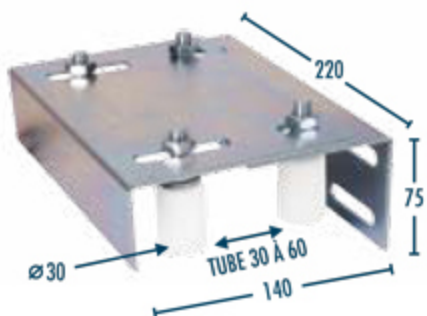

FN3650

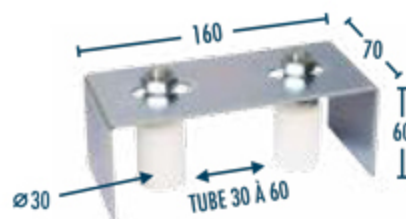

FN3651



FN36512



FN36511



FN3655
270 X 35

ÉPAISSEUR 6

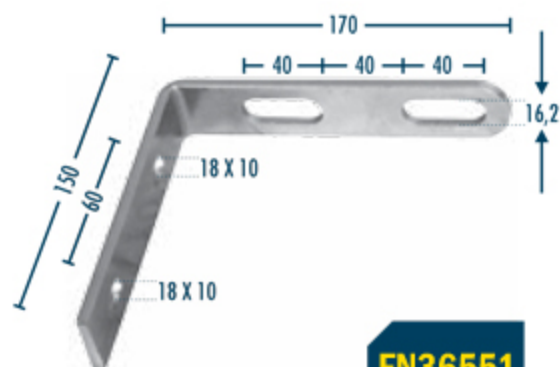

FN36551
170 X 150

ÉPAISSEUR 6